

ClearPlus Under Sink Drinking Water System

OWNER'S MANUAL AND INSTALLATION GUIDE

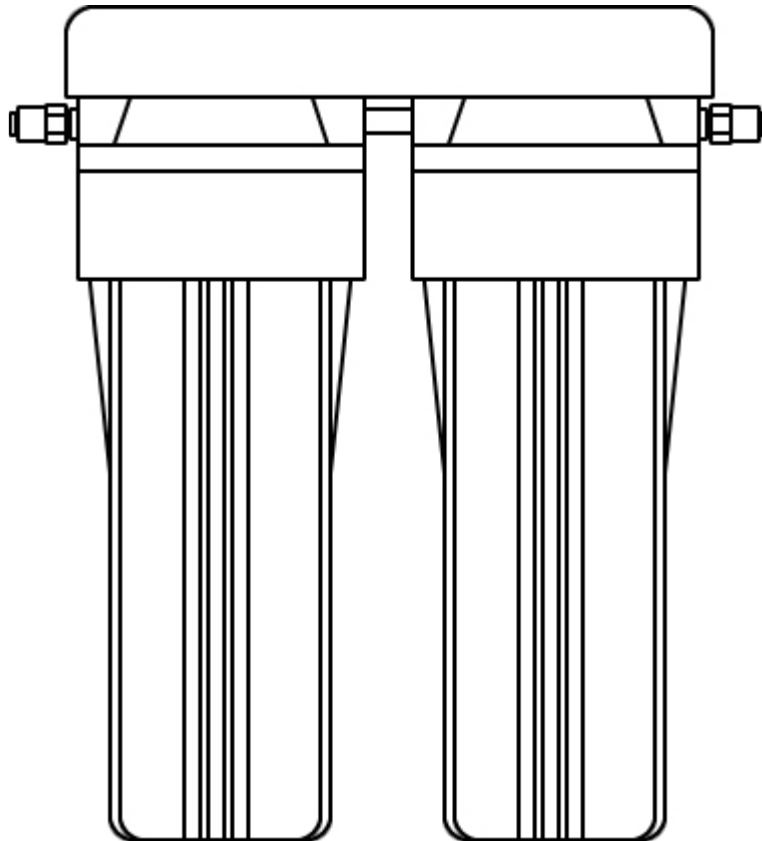

**PLEASE READ THIS MANUAL CAREFULLY
BEFORE ATTEMPTING INSTALLATION**

Congratulations on the purchase of your ClearPlus *Under Sink Drinking Water System*.

This filtration system uses premium quality filters rated as low as 5 microns to remove fine sediments, chlorine, and organic contaminants responsible for poor water taste and odor. It is also capable of removing a wide variety of potentially harmful trace contaminants.

You can rest assured that you have made a solid investment in the quality of your drinking water!

INSTALLATION

We recommend that you read the entire instructions before commencing the actual installation.

Note: The maximum recommended operating water pressure is 80 PSI. If your home water pressure is greater than 80 PSI, you should have a pressure reduction valve installed by a certified plumber prior to installing this product.

Step 1. – Pre-Installation Inspection

Inspect all of the components that you received with your unit. You should have received the following:

- 2-stage filtration unit assembly with mounting bracket (this is pre-assembled)
- chrome-finished long-reach faucet and hardware
- water tubing
- quick connect fitting
- self-piercing “C” clamp saddle valve and related hardware
- 1 filter
- 1 carbon filter
- spanner wrench

If you are missing any components, please call us immediately for assistance.

Step 2. – Install Stage 1 Sediment Filter

Unscrew the sump (the vessel that holds the actual filter cartridge) from the housing cap / mounting bracket assembly. The Stage 1 sediment filter is white and looks like a tightly spun cotton ball. It is installed in the sump on the left side when facing the front of the unit. Remove the protective plastic film that protects the sediment pre-filter and install it in the sump. Make sure that it slips down over the sump standpipe (the raised portion at the bottom of the inside of the sump). This will ensure that the filter is properly centered in the housing. Turn the sump onto the housing cap and hand tighten. Make sure that the filter slips over the cap standpipe. Do not over-tighten!

Step 3. – Install Stage 2 Carbon Filter

Follow the instructions in Step 2. to install the stage 2 carbon filter in the sump on the right hand side of the unit. The Stage 2 carbon filter is white in color with blue end caps.

Step 4. – Select an Installation Site

Your water filter system was designed to be compact enough to fit under most kitchen sinks. However, the system may be installed in a basement, closet, crawl, space, or wherever it is most convenient. If you select an alternative installation area other than under your kitchen sink, you may need to purchase some additional water tubing which is generally available at any hardware store. When determining the installation site, access to a cold water line is important. To accommodate filter changes, we recommend that you leave at least 4 inches of clearance beneath the filter housing sumps.

Step 5. – Mount the Filtration Unit Assembly

The mounting bracket has pre-drilled keyhole slots for easy mounting to the wall of your kitchen cabinet, wall, or other suitable sturdy base. Using the bracket itself as a template, mark the location for the mounting screws. Then, drill 1/8” pilot holes (this will make it easier to set the screws). Install 2 suitable screws and tighten them until the heads are about 1/8” from the wall. Hang the filtration unit assembly on the mounting screws and then hand tighten the screws.

Step 6. – Drill Hole for the Faucet

The faucet should be installed in a manner that all overflow will run into your kitchen sink. This will require you to drill a hole in either your countertop immediately adjacent to the sink, or in the sink itself (usually the sink itself), unless you have an unused or capped hole already present.

Locate a desirable location for your faucet. Most homeowners prefer to mount the faucet in the rear left corner of the sink or on the back edge to the left of the main faucet. Make sure that you will be able to access the threaded portion of the faucet on the under sink of the sink/countertop following installation – you will need access to this to attach the water line connections.

For Stainless Steel Sinks:

- make a small indent with a center punch as a starting point for drilling
- drill a pilot hole with a 1/8” or similar sized bit
- drill hole for the faucet with 1/2” bit

For Porcelain Enamel Sink:

- place a piece of tape over the area to be drilled to help prevent chipping of the porcelain
- drill a pilot hole with a carbide-tip pilot drill bit (1/8”) - when drilling, drill slowly and carefully.
- drill out hole for the faucet with a 1/2” porcelain cutter kit
- remove tape and clean away any small chips

For Formica Countertop:

- counter must be at least 5/8” thick
- drill a pilot hole with a 1/8” or similar bit

- drill hole for the faucet with 1/2" bit

For Ceramic Tile Countertop:

- counter must be at least 5/8" thick
- follow steps for Porcelain sink

Step 7. – Install the Faucet

Slide the 1 1/4" rubber washer, chrome faceplate and 1 7/8" rubber gasket on to the threaded faucet stud. These parts will sit above the sink/countertop.

Place the threaded faucet stud through the hole in the sink / countertop and position the faucet, handle and faceplate with the gasket.

From the underside of the counter, slide the black plastic washer, the lock washer, and faucet nut onto the threaded faucet stud.

Tighten the faucet nut while holding the faucet in position with a padded crescent wrench. Do not over-tighten. It only needs to be hand tight.

Once the faucet is installed, place a couple of wraps of Teflon tape on the bottom of the threaded section and attach the plastic quick connect faucet adapter fitting.

See diagram for details.

Step 8. – Install the Saddle Valve for Feed Water Supply

Caution: Do not connect the saddle valve to the hot water pipe. This system is designed to be used with a cold water supply only (maximum 100F / 37c).

The saddle valve may be installed on copper tube, or iron, brass, steel, or CPVC pipe as follows:

Installing on soft copper tubing:

1. Turn off the water supply and drain the line by opening a nearby faucet until the water stops running.
2. Turn the saddle valve handle counter clockwise (outward) until the lance does not protrude from the black gasket.
3. Position the saddle valve around the tubing as shown in the diagram and insert the back plate. Note that the back plate is reversible depending on whether you have 3/8" or 5/8" diameter tubing. Match the back plate so that it fits your pipe diameter as close as possible.
4. While holding the saddle valve in place, tighten the brass screw to secure the valve firmly against the pipe.

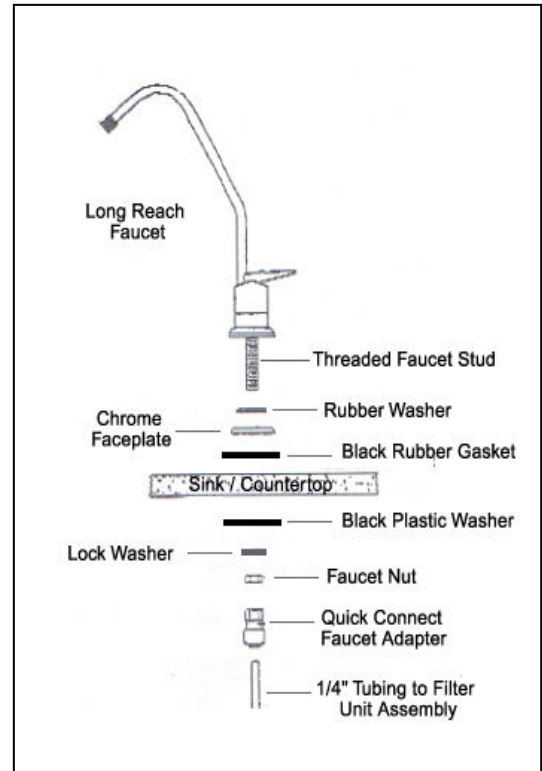

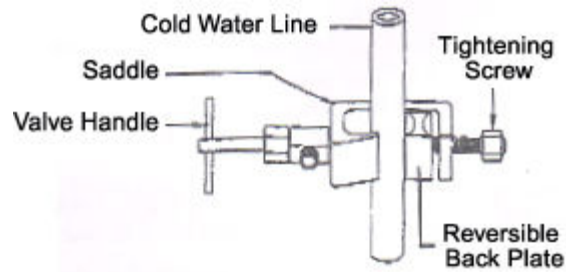

5. To pierce the tubing, turn the valve handle clockwise (inward) until it becomes fully seated. At this point the tube has been pierced and sealed and the valve is closed.
6. Keep the saddle valve closed for now, but turn on the water supply again. Turn on the main kitchen sink faucet to flush any debris from the water line from the installation, and inspect the saddle valve for leaks. Ensure any leak found is corrected before proceeding.

Installing on hard steel, iron, brass, or CPVC pipe:

1. Turn off the water supply and drain the line by opening a nearby faucet until the water stops running.
2. Drill a 3/16" hole into the supply line (be careful not to drill through the opposite wall of the pipe!). Use a hand-drill or battery-powered drill to reduce the risk of electric shock.
3. Turn the saddle valve handle until the lance appears no more than 3/16" beyond the rubber gasket.
4. Place the lance over the hole in the supply line so that the lance fits into the hole. Insert the back plate. Note that the back plate is reversible depending on whether you have 3/8" or 5/8" diameter tubing. Match the back plate so that it fits your pipe diameter as close as possible.
5. While holding the saddle valve in place, tighten the brass screw to secure the valve firmly against the pipe.
6. To pierce the tubing, turn the valve handle clockwise (inward) until it becomes fully seated. At this point the tube has been pierced and sealed and the valve is closed.
7. Keep the saddle valve closed for now, but turn on the water supply again. Turn on the main kitchen sink faucet to flush and debris from the water line from the installation, and inspect the saddle valve for leaks. Ensure any leak found is corrected before proceeding.

Step 9 – Water Line Connections

1. Determine what length of water tubing is needed to extend from the saddle valve on the supply line to the left side (inlet) of the water filtration unit assembly and cut a section of 1/4" tubing for this purpose. Make sure that you cut the tubing straight across (not on an angle) and that all burrs or rough edges are removed. Be sure to allow for some "slack" so there is some ability to move the unit around under the sink in the future if necessary and to facilitate maintenance.
2. Slide the brass compression nut and white plastic ferrule over the water tubing. Then place the plastic or brass insert into the tube.
3. Attach the tubing to the inlet of the saddle valve by tightening the brass compression nut. Tighten with a wrench but do not over-tighten. Extreme force is not necessary.

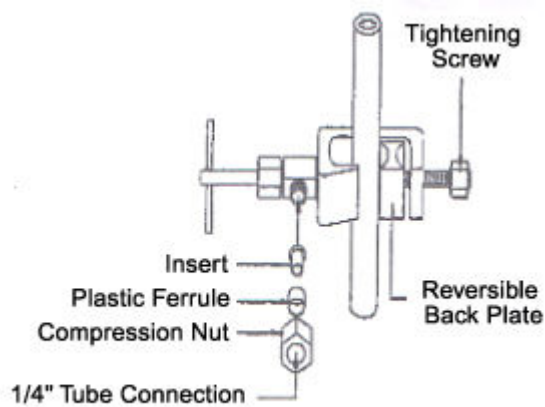

4. Insert the other end of the 1/4" tube into the left side (inlet) of the water filtration unit. This connection is a "quick connect" adapter and does not require a tube insert. Push the tube into the fitting as far as it will go. Excessive force is not necessary. It will lock in place and seal automatically.

5. Determine what length of water tubing is needed to extend from the right side (outlet) of the water filtration unit assembly to the faucet and cut a section of 1/4" tubing for this purpose. Make sure that you cut the tubing straight across (not on an angle) and that all burrs or rough edges are removed. Be sure to allow for some "slack" so there is some ability to move the unit around under the sink in the future if necessary and to facilitate maintenance.

6. Insert one end of the tubing into the quick connect adapter on the right side (outlet) of the water filtration unit assembly and the other into the quick connected adapter previously installed on the faucet. Push the tube into the fitting as far as it will go. Excessive force is not necessary. It will lock in place and seal automatically

Step 10 – System Start-Up Procedure

1. Slowly open the saddle valve on the feed water supply line. Then turn on the faucet at the sink. The unit should begin to process the water. The initial flow of water may be discolored due to the release of carbon fines (black), and/or it could be cloudy due to the presence of tiny air bubbles in the water. This is normal. It will go away in a few minutes.
2. Inspect all of the water connections carefully for leaks. If any leaks are found, immediately turn off the water supply at the saddle valve and correct the reason for the leak and start the System Start-Up Procedure again.
3. If there are no leaks, allow the water to run for at least 5 minutes to prime the filter and purge the carbon fines.
4. You are now ready to start enjoying fresh water from your system!

SYSTEM MAINTENANCE

Your under sink water filtration system is designed for low maintenance operation, however, the filter cartridges do need to be replaced periodically, roughly every 1000 gallons (3,785 L) for optimal performance. It is important to note that filter clogging is not a reliable method of determining filter life as the capacity to remove certain contaminants can be exhausted before the

filter physically clogs. We recommend that the sediment pre-filter and carbon block filter be replaced at least every 1,000 gallons (3,785 L) or every 12 months to ensure optimal contaminant removal. In rare cases, the filter(s) may clog before this time in which case filter replacement would be necessary to restore water flow.

Replacement Filters:
Sediment Pre-Filter: Hydronix SDC-25-1005
Carbon Filter: Hydronix CB-25-1010
To purchase replacement filters, call 1-866-376-2690

Filter replacement procedure:

1. Turn off the feed water supply to the system by closing the saddle valve on the feed water supply line.
2. Open the dispensing faucet and leave it open – this will help purge the vacuum that can build in the housing when the water is turned off.
3. Unscrew the filtration unit sumps (bottom part of the filter housings) using the spanner wrench.
4. Remove the O-rings from the sumps and wipe the grooves to make sure they are clean. Note: If O-rings appear stretched, crimped, torn, or damaged in any other way, they should be replaced.
5. Remove the old cartridges and discard. Rinse out the sumps and fill about 1/3 full with hot soapy water. Add about 2 to 3 teaspoons of bleach to each sump and scrub with a brush or sponge (wear rubber gloves to protect your hands). Rinse thoroughly.
6. Re-install the O-rings and coat them with a food-grade silicone lubricant or glycerin. **Do not use petroleum-based lubricants such as Vaseline.** Press the O-rings into the grooves and make sure they are seated evenly. **This step is important to ensure proper filter seal.**
7. Install the replacement cartridges as per Steps 2 and 3 in the Installation Instructions and then follow Step 10 – System Start-up Procedure.

To prevent possible repairs and water damage, we strongly recommend that the sumps of all plastic housings be replaced roughly every 10 years.

Sanitizing the System

Additional sanitizing of the system is recommend in conjunction with filter replacement, at least on an annual basis (this process must be done without the filters installed):

1. After removing the old filter cartridges and cleaning the sumps, add approximately 1 ounce of bleach to the Stage 1 filter housing (left) and re-attach both sumps to the filter unit assembly.
2. Turn on the feed water supply and open the faucet and let the unit run until you begin to smell the bleach at the faucet. Turn off the faucet and let the system sit for 6 hours or overnight.
3. After at least 6 hours, turn on the feed water supply at the saddle valve and run the system for a minimum of 10 minutes. The unit has been sterilized. Follow the procedures for filter replacement as noted above.