



WH5B

Iron / Hydrogen Sulfide Reduction Filter Package w/ Sediment Pre-Filter



Package Contents:

- two (2) heavy-duty Pentek Big Blue 20" filter housing (1" NPT) w/ pressure relief button
- one (1) mounting bracket and related lag bolts and washers
- one (1) Pentek RFFE20-BB radial flow iron reduction filter cartridge
- one (1) Pentek DGD-5005-20 sediment pre-filter
- one (1) spanner wrench
- one (1) 1" housing coupler used to join the 2 filter housings
- one (1) roll of Teflon tape

The WH5B iron / hydrogen sulfide reduction filter package combines an effective oxidation filter with pre-filter treatment to create an excellent all-round home water treatment system for the removal of low to moderate levels of dissolved (ferrous) iron. The iron reduction filter cartridge itself contains manganese dioxide media which reduces iron, manganese, and hydrogen sulfide through an oxidation / filtration process, thereby substantially improving water clarity, taste, and odor, while at the same time protecting your plumbing system including toilets, bath tubs and showers, and appliances such as clothes washers and dishwashers, from unsightly staining. It does NOT add any harmful chemicals to the water, making it completely safe for drinking water applications. The sediment pre-filter removes sediment down to a level of 5 microns.

This system should be employed where low to moderate ferrous (dissolved) iron, manganese, or hydrogen sulfide contamination is known or expected. This filter will also remove ferric iron through mechanical filtration. This filter is most effective where iron contamination level is less than 3 ppm (and no greater than 5 ppm) or the hydrogen sulfide level is less than about 2 ppm. If a combination of iron, manganese, and hydrogen sulfide are present, you must consider the "iron equivalent" level when determining if this filter will work effectively in your circumstance (see below). Best contaminant removal rates are achieved where the pH is 7.0 or higher, although satisfactory contaminant removal can generally be achieved at slightly lower pH levels (6.8 to 6.9) under most conditions. This filter is not recommended where pH levels are less than 6.8.

The life of the primary filter depends on the contamination level ("iron equivalent") and amount of water consumed on a daily basis. You can get a good idea of how long a filter will last in your case by using the chart below.

"Iron Equivalent" is calculated as follows:

$$(\text{Iron level}) + (2 \times \text{Manganese level}) + (3 \times \text{Hydrogen sulfide level})$$

If your level of Hydrogen sulfide is unknown (it is hard to accurately test for) and you have a noticeable "rotten egg" odor, assume a Hydrogen sulfide level of 0.5 ppm. If the rotten egg odor is severe, assume a level of 1.0 ppm.

Example: Test results are 0.8 ppm iron, 0.2 ppm manganese, and you have a rotten egg smell in your water. Iron Equivalent = $(0.8) + (2 \times 0.2) + (3 \times 0.5) = 2.7$

Approximately life of a RFFE20-BB filter cartridge:

Iron Equivalent Level in Water	Total Gallons Water Used	250 GPD (four people)	125 GPD (two people)	75 GPD (one person)
5 ppm	16,000 gal	64 days	128 days	256 days
4 ppm	20,000 gal	80 days	160 days	320 days
3 ppm	26,000 gal	104 days	208 days	416 days
2 ppm	40,000 gal	160 days	320 days	640 days
1 ppm	80,000 gal	320 days	640 days	1280 days
0.5 ppm	160,000 gal	640 days	1280 days	n/a

Specifications	
Housing Material:	Polypropylene
Housing O-Ring Material:	Buna-N
Housing Pressure Drop:	1 PSI at 15 Gallons Per Minute (0.1 bar at 57 LPM)
RFFE20-BB Filter Pressure Drop:	<2 PSI @ 6 Gallons Per Minute (<0.2 bar @ 23 LPM)
DGD-5005-20 Filter Pressure Drop:	<1 PSI @ 20 Gallons Per Minute (<0.1 bar @ 76 LPM)
Maximum Recommended Flow Rate:	6 Gallons Per Minute (23 LPM)
Recommended Operating Temp. Range:	40-100°F (4.4 to 37°C)
Maximum Recommended Pressure:	90 PSI (6.2 bar)

Typical Installation:

Note: We recommend that this product be installed by a professional plumber. If you install this product yourself, please ensure that your installation meets all local building and plumbing codes. The following instructions are meant only as a general guide and should not be considered a substitution for your local plumbing and / or building codes.

You will need the following plumbing supplies:

- two (2) shut-off valves with suitable sized unions to connect to your incoming and outgoing water lines. You can select threaded, compression or sweat (soldered) fittings on the shut-off valves as desired.
- plumber's cement or Teflon tape for all threaded fittings.

The plumbing connections on the inlet and outlet of the water filter housings are 1" inside diameter (female) NPT threaded fittings. You may require additional plumbing adapters to connect to your selected shut-off valves. Your plumber will have all of these items, or they can be purchased at your local hardware or plumbing supply store at minimal cost (take these

instructions to the store with you so the store clerk can make sure you get everything you need).
Note: In older homes with galvanized piping all fittings should be threaded.

STEP 1. Select an installation location. There are a variety of ways to install your filter system into a main or branch water line. As a general recommendation, this system should be installed on the main **cold water line** after the pressure tank or water meter. Select an installation location with convenient access for regular filter replacements and maintenance.

STEP 2. Shut off the main water supply and drain the pipes. Opening the highest and lowest fixtures in the house will help drain the pipes.

STEP 3. Using a pipe cutter, cut out a section of your main water line at the point where you want to install your filter system. There will probably be some water remaining in the system, so be sure to have a bucket and some rags handy to clean up any small spills. Make sure that the section of water line you remove is appropriately sized such that all of the components of the system including the shut-off-valves, adapters, and the black filter caps will fit snugly when assembled. If in doubt, cut a smaller section at first – you can always remove a slightly larger section upon final assembly if necessary.

STEP 4. Assemble the components according to Diagram 1 below. Use the 1" housing coupler provided with this package to connect the 2 black housing caps. We recommend installing shut-off valves both upstream and downstream of the filter housings. A shut-off valve is not required on the upstream side of the housing if the filter will be located within a couple of feet of the main line shut-off valve. **Plumber's cement or Teflon tape should be used on all threaded fittings.** Secure the mounting bracket to the black cap of the filter housing using the lag bolts and washers provided. Secure the bracket to the wall with suitable anchors based on the material of your wall. Remember that the filters will be heavy when full of water so secure to the wall well. Allow enough space below the black cap to accommodate the blue housing sumps plus a minimum of an additional 3 inches of clearance.

IMPORTANT WARNINGS:

Use extreme caution when soldering any connections between the main water line and the shut-off valve or between the shut-off valves & filter housings if your filter housings are connected to the pipes, or serious damage to the filter housings could occur. If at all possible, solder all connections before the pipe is connected to the filter housings.

If your water pipes are metal (galvanized or copper), they may be used to ground electrical systems, appliances, or your phone line. If this is the case, be sure to install regulation ground clamps to the metal pipe on each side of the plastic filter housing and connect a jumper wire between the 2 clamps (#4 gauge solid copper wire recommended). Alternatively, your plumbing code MAY allow you to connect the jumper wire to the 2 shut-off valves (see diagram). Consult a certified electrician or plumber if you are unsure.

Diagram #1

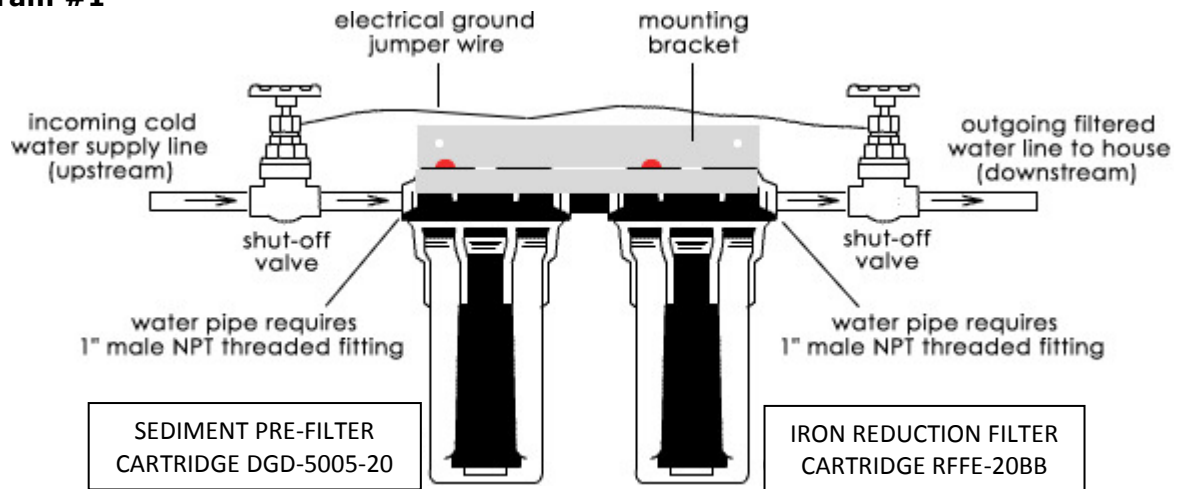

STEP 5. Remove the protective plastic wrap from one of the filter cartridges and place it in the appropriate blue housing sump. At the bottom of the sump, there is a raised portion in the middle (standpipe) that will help center the filter in the housing. The standpipe will fit inside the hole that runs through the middle of the filter cartridge. Check to make sure that the O-ring is seated properly in the groove at the top of the blue housing sump, then screw the blue housing sump containing the filter cartridge onto the black housing cap. Use the spanner wrench to tighten. Repeat this step for the other filter. Store any spare filters in a cool dry place for future use.

STEP 6. Turn on the water and inspect all plumbing connections very carefully for leaks. Also inspect the seal between the black housing caps and the blue housing sumps to ensure that the O-ring has formed a good seal. Tighten this connection again using the spanner wrench if necessary. If this connection still leaks, turn off the water supply and check to make sure that the filter is aligned properly in the housing and repeat your test for leaks. When you are confident that all connections are sound, run cold water for 5 minutes at any faucet to purge air out of your system and flush the filter before use. New cartridges may release "fines" (very fine black powder) after installation. Wait one hour, and flush again for another 5 minutes prior to using the water.

Important Notes:

1. The manufacturer recommends that the blue housing sumps be replaced every 10 years or if you notice any cracks or damage.
2. This filter system should not be used with water that is microbiologically unsafe or of unknown quality without adequate disinfection before and/or after the system.
3. Water filter systems should never be exposed to freezing temperatures - severe damage to the filter and housings could result. Such damage is not covered under any warranty.
4. After prolonged periods of non-use (such as a vacation), it is recommended that the system be flushed thoroughly for at least 5-10 minutes before using the water.
5. The contaminants or other substances removed or reduced by this water treatment device are not necessarily in your water.

6. If you suspect that your water pressure will at any time exceed the maximum rating of 90 PSI (6.2 bar), a pressure regulator must be installed before the system. It is recommended that the pressure regulator be set at 75 PSI (5.2 bar) or less.

Maintenance and Filter Replacement Information:

To maintain the optimal performance of your whole house water filter system, filters should always be replaced in accordance with manufacturer specifications. Filters may need to be replaced more frequently than specified, depending on the level of contaminants, particularly sediments, in your water supply. If significant water pressure reduction is noticed, the filter may have become clogged. We recommend that you keep a "Filter Replacement Log" attached to your system where you can record the date of filter changes, and that you write a note on your household calendar reminding you of filter replacement schedules.

Replacement Filters: Pentek RFFE20-BB & Pentek DGD-5005-20

Replacement Filters can be Obtained as Follows:

Phone Toll Free 1-866-376-2690 or
Order Online at: www.home-water-purifiers-and-filters.com

Filter Cartridge Replacement Procedure:

1. Turn off the water supply to the system using the shut-off valves you installed on the inlet and outlet of the filter housing. Depress the red pressure release button on the top of the filter housing cap to allow any pressure inside the housing to escape, thereby allowing the blue filter sump to be removed easier.
2. Unscrew the blue sump (bottom of the housing) from the cap using your spanner wrench (included with original purchase of your system).
3. Locate and remove the large O-ring. Try not to remove any of the lubricant. The housing O-ring should be replaced at least once annually or at each filter change if any damage to the O-ring is noted (kinked, cracked, stretched, etc.), or if any leakage between the black housing cap and the blue housing sump is detected and does not seal after tightened with the spanner wrench. Put the O-ring in a safe place where it will not get dirty or otherwise contaminated. **Replacement O-Ring: Pentek Buna-N Big Blue O-Ring #151122**
4. Take out the old filter cartridge and discard it.
5. Scrub the bottom of the housing and cap with dish soap and warm water using a sponge or soft cloth. Fill 1/3 with water and add about 2 tablespoons of household bleach. Scrub to disinfect (we recommend that you use rubber gloves). **Rinse all parts thoroughly!**

6. Lubricate the O-ring with food-grade silicon lubricant if needed. Insert O-ring in the groove at the top of the blue sump and press into place. **Make sure the O-ring is seated level in the groove!**
7. Remove the protective plastic wrapping from the new filter cartridge and insert the cartridge into the housing sump, making sure that it slips over the standpipe in the bottom of the housing.
8. Screw the blue sump onto the black housing cap tighten using the spanner wrench. **Do not over tighten.**
9. Turn on the water supply slowly to allow the system to fill with water. Depress the red pressure release button on top of the unit again to release any trapped air. **Inspect carefully for leaks.** If a leak is found, first inspect the O-ring to ensure that it is seated properly before tightening the sump more. Tighten using the spanner wrench as necessary to achieve a good seal and stop leaks.
10. New cartridges may contain "fines" (very fine black powder) after installation. Flush the system by running water from a nearby faucet for 5 minutes. Wait one hour, and flush again for another 5 minutes prior to using the water.