

Owner's Manual

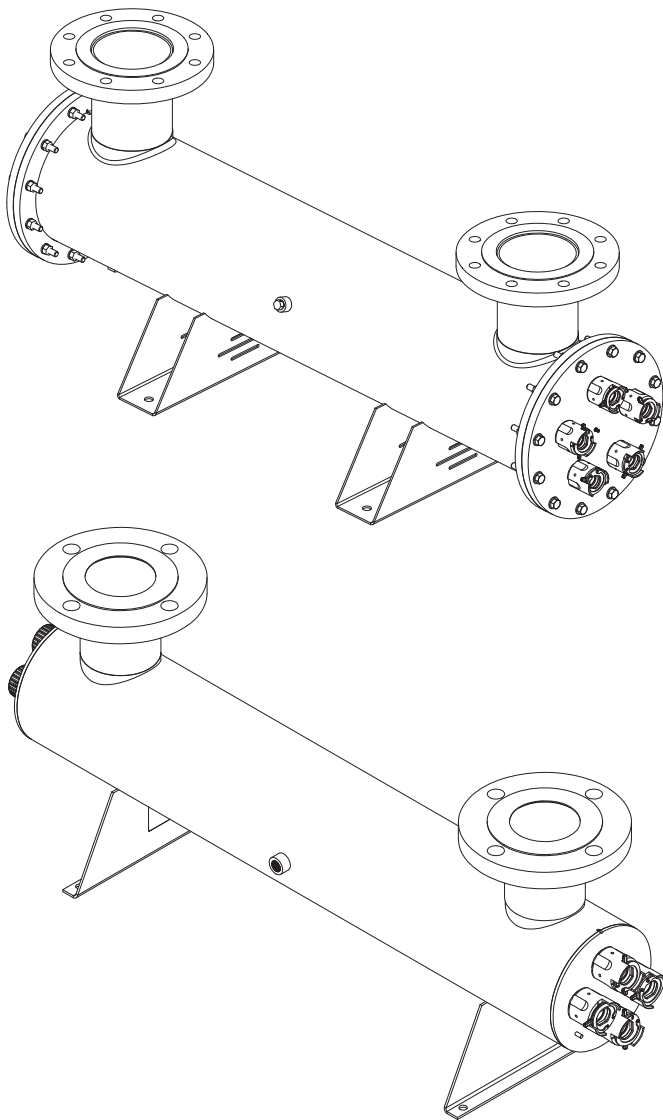

Models:

SHF-140, SHFM-140,
SHF-180, SHFM-180
SHF-290, SHFM-290

Powered by
Sterilight

Congratulations

on the purchase of your ultraviolet (UV) water disinfection system! This system uses the most advanced UV technology on the market and is designed to provide you with years of trouble free operation with minimal maintenance required to protect your drinking water from microbiological contaminants.

To ensure ongoing disinfection of your water, UV lamps need to be replaced annually with VIQUA factory-supplied replacements. VIQUA lamps are the result of extensive development resulting in a highly efficient disinfection platform with extremely stable UV output over the entire 9000 hour lifetime. Its success has led to a proliferation of non-genuine copies in the market.

The UV lamp is the heart of the disinfection system, and there should be no compromise when it's time for a replacement.

Why should you insist on genuine factory supplied VIQUA replacement lamps?

- Use of widely available, non-genuine, replacement lamps has been shown to damage the control module of VIQUA UV disinfection equipment.
- An increasing number of calls to VIQUA Technical Support are connected with non-genuine lamps being used (unknowingly) as replacements.
- Damage arising from the use of non-genuine lamps poses a safety risk and is not covered by equipment warranty.
- Unless the UV equipment is equipped with a UV sensor (monitor), it is not possible to verify the UV (invisible) output of replacement lamps.
- Similar appearance to the original lamp and the presence of (visible) blue light does not mean equivalent disinfection performance.
- VIQUA replacement lamps undergo rigorous performance testing and strict quality control processes to ensure that the safety and performance certifications of the original equipment are not compromised.

So, you can see that it's simply not worth the risk! Insist on genuine VIQUA replacement lamps.



















Section 1 Safety Information

These are the original instructions. Please read this entire manual before operating this equipment. Pay attention to all danger, warning, and caution statements in this manual. Failure to do so could result in serious personal injury or damage to the equipment.

Make sure that the protection provided by this equipment is not impaired. Do not use or install this equipment in any manner other than that specified in the installation manual.

1.1 Potential Hazards



Read all labels and tags attached to the system. Personal injury or damage to the system could occur if not observed.

	Waste electrical and electronic equipment (WEEE). This symbol indicates that you should not discard wasted electrical or electronic equipment (WEEE) in the trash. For proper disposal, contact your local recycling/reuse or hazardous waste center.		This symbol indicates that the contents of the transport package are fragile and the package should be handled with care.
	This symbol indicates there is Mercury present.		This symbol indicates to secure the device with a safety device / hook.
	This is the safety alert symbol. Obey all safety messages that follow this symbol to avoid potential injury. When on the equipment, refer to the Operational and Maintenance manual for additional safety information.		This symbol indicates safety glasses with side protection is required for protection against UV exposure.
	This symbol indicates a risk of electrical shock and/or electrocution exists.		This symbol indicates gloves must be worn.
	This symbol indicates the marked equipment may contain a component that can eject forcibly. Obey all procedures to safely depressurize.		This symbol indicates safety boots must be worn.
	This symbol indicates the system is under pressure.		This symbol indicates a hard hat must be worn.
	This symbol indicates there is a potential UV hazard. Proper protection must be worn.		This symbol indicates the operator must read all available documentation to perform required procedures.
	This symbol indicates the marked item could be hot and should not be touched without care.		This symbol indicates the plumber must use copper piping.
	This symbol indicates there is a potential for VERY hot water when flow is started.		This symbol indicates that the system should only be connected to a properly grounded, grounding-type controller receptacle that is protected by a Ground Fault Circuit Interrupter (GFCI).
	This symbol indicates not to store any combustible or flammable material close to the system.		

Warning: This product may contain chemicals known to the State of California to cause cancer and birth defects or other reproductive harm.

1.2 Safety Precautions

⚠ DANGER

 	<p>Failure to follow these instructions will result in serious injury or death.</p> <ul style="list-style-type: none"> • Electric Shock: To avoid possible electric shock, special care should be taken since water is present near the electrical equipment. Unless a situation is encountered that is explicitly addressed by the provided maintenance and troubleshooting sections, do not attempt repairs yourself, refer to an authorized service facility. • GROUNDING: This product must be grounded. If it should malfunction or breakdown, grounding provides a path of least resistance for electric current to reduce the risk of electrical shock. This system is equipped with a cord having an equipment-grounding conductor and a grounding plug. The plug must be plugged into an appropriate outlet that is properly installed and grounded in accordance with all local codes and ordinances. Improper connection of the equipment-grounding conductor can result in a risk of electrocution. Check with a qualified electrician or service personnel if you are in doubt as to whether the outlet is properly grounded. Do not modify the plug provided with this system – if it does not fit in the outlet, have a proper outlet installed by a qualified electrician. Do not use any type of adapter with this system. • GROUND FAULT CIRCUIT INTERRUPTER PROTECTION: To comply with the National Electrical Code (NFPA 70) and to provide additional protection from the risk of electric shock, this system should only be connected to a properly grounded, grounding-type controller receptacle that is protected by a Ground Fault Circuit Interrupter (GFCI) or to a residual current device (RCD) having a rated residual operating current not exceeding 30 mA. Inspect operation of GFCI as per manufacturer’s suggested maintenance schedule. • DO NOT operate the disinfection system if it has a damaged cord or plug, if it is malfunctioning or if it has been dropped or damaged in any manner. • DO NOT use this disinfection system for other than intended use (potable water applications). The use of attachments not recommended or sold by the manufacturer / distributor may cause an unsafe condition. • DO NOT install this disinfection system where it will be exposed to the weather or to temperatures below freezing. • DO NOT store this disinfection system where it will be exposed to the weather. • DO NOT store this disinfection system where it will be exposed to temperatures below freezing unless all water has been drained from it and the water supply has been disconnected.
--	--

Safety Information

⚠ WARNING



- During extended periods of no water flow, the water in your chamber can become very hot (Approx. 60 °C) and potentially lead to scalding. It is recommended to run your water until this hot water has been purged from your chamber. Do not allow water to contact your skin during this time. To eliminate this condition, a temperature management valve can be installed at the outlet of your UV system.
- This system contains a UV Lamp. Do not operate the UV Lamp when it is removed from the chamber. Unintended use or damage of the system may result in the exposure of dangerous UV radiation. UV radiation may, even in little doses, cause harm to the eyes and skin.
- Changes or modifications made to this system without the consent of the manufacturer could render the system unsafe for operation and may void the manufacturer's warranty.

Body Crush Hazard

- Failure to follow these instructions could result in serious injury or death due to improper lifting procedures, underrated lifting equipment and, moving parts.
- ALWAYS secure with safety device.
- ALWAYS stay clear of elevated loads.
- ALWAYS comply with local safety regulations.

⚠ CAUTION



Failure to follow these instructions could result in minor or moderate injury.

- Carefully examine the disinfection system after installation. It should not be plugged in if there is water on parts not intended to be wet such as, the controller or lamp connector.
- Due to thermal expansion concerns and potential material degradation due to UV exposure, it is recommended to use metal fittings and at least 10" of copper pipe on the outlet of your UV chamber.

For industrial use only.



- During normal operation, Control Panel must be locked using the key and padlock supplied.
- **Hg EXPOSURE:** The UV lamp contains mercury. If the lamp breaks, then avoid inhalation or ingestion of the debris and avoid exposure to eyes and skin. Never use a vacuum cleaner to clean up a broken lamp as this may scatter the spilled mercury. Obey local regulations and guidelines for the removal and disposal of mercury waste.

NOTICE



- The UV lamp inside the disinfection system is rated at an effective life of approximately 9000 hours. To ensure continuous protection, replace the UV lamp annually.
- The UV system is not to be used or played with by children. Persons with reduced physical, sensory or mental capabilities, or lack of experience and knowledge, are also not to handle the UV system unless they have been given supervision or instruction.
- This system is intended to be permanently connected to the water lines.
- This system is not intended to be used in or above water or outdoors or used in swimming pools when persons are in the pool.
- **EXTENSION CORDS:** If an extension cord is necessary, use only 3-wire extension cords that have 3-prong grounding-type plugs and 3-pole cord connectors that accept the plug from this system. Use only extension cords that are intended for outdoor use. Use only extension cords having an electrical rating not less than the rating of the system. A cord rated for less amperes or watts than this system rating may overheat. Exercise caution when arranging the cord so that it will not be tripped over or pulled. DO NOT use damaged extension cords. Examine extension cord before using and replace if damaged. DO NOT abuse extension cord. Keep extension cord away from heat and sharp edges. Always disconnect the extension cord from the receptacle before disconnecting this system from the extension cord. Never yank cord to pull plug from outlet. Always grasp the plug and pull to disconnect.
- If the supply cord is damaged, it must be replaced by a special cord or assembly available from the manufacturer or its service agent.
- **SYSTEM PROTECTION:** To protect your Controller, a UL1449 certified (or equivalent) transient voltage surge suppressor is strongly recommended.
- The UV lamp in this system conforms to the applicable provisions of the Code of Federal Regulations (CFR) requirements including, Title 21, Chapter 1, Subchapter J, Radiological Health.
- Read and understand the Owner's Manual before operating and performing any maintenance on this equipment.

1.3 Water Chemistry

Water quality is extremely important for the optimum performance of your UV system. The following levels are recommended for installation:

Water Quality and Minerals	Level
Iron	< 0.3 ppm (0.3 mg/L)
Hardness*	< 7 gpg (120 mg/L)
Turbidity	< 1 NTU
Manganese	< 0.05 ppm (0.05 mg/L)
Tannins	< 0.1 ppm (0.1 mg/L)
UV Transmittance	> 75% (call factory for recommendations on applications where UVT < 75%)

* Where total hardness is less than 7 gpg, the UV unit should operate efficiently provided the quartz sleeve is cleaned periodically. If total hardness exceeds 7 gpg, the water should be softened. If your water chemistry contains levels in excess of those mentioned above, proper pre-treatment is recommended to correct these water problems prior to the installation of your UV disinfection system. These water quality parameters can be tested by your local dealer, or by most private analytical laboratories. *Proper pre-treatment is essential for the UV disinfection system to operate as intended.*

Section 2 General Information

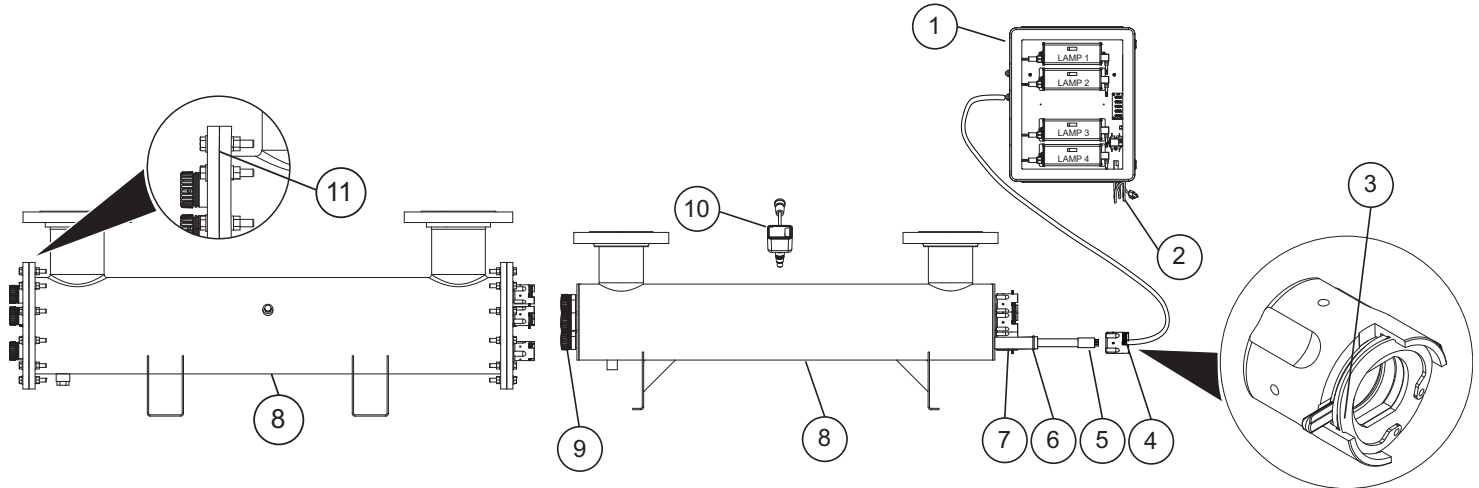

Figure 1 System Components

Item	Description	Part Number	UV Systems
1	Controller	BA-ICE-HF	SHF series, SHFM series
		BA-ICE-M-HF	SHFM series
2	Replacement power cords for Hi-Flo ICE Controller (sold separately)	260223R-001	NORTH AMERICAN (NEMA 5-15P), 3-PRONG GROUNDED
		260223R-002	CONTINENTAL EUROPEAN (CEE 7/7) 2-PIN WITH GROUND, "SCHUKO"
		260223R-003	AUSTRALIAN VERSION (AS 3112) 3-PRONG GROUNDED
		260223R-004	UK VERSION (BS 1363) 3-PRONG GROUNDED (5 AMP FUSE)
		260193-R	NO CONNECTOR, 3-WIRE, BARE LEADS
3	Retaining nut assembly	-	Used on all Models
4	Lamp Harness	260227-R	SHFM-140, SHFM-140/2, SHFM-180, SHFM-180/2
		270278-R	SHFM-290, SHFM-290/2
5	Hard glass, coated CIRCLINE-HO UV lamps for long, consistent life (9000 hours)	S740RL-4C	SHF-140, SHF-140/2, SHFM-140, SHFM-140/2
		S950RL-4C	SHF-180, SHF-180/2, SHFM-180, SHFM-180/2; SHF-290, SHF290/2, SHFM-290, SHFM-290/2
6	O-ring	410867	Used on all Models
7	214 fused quartz sleeves with fire polished ends	QS-012	SHF-140, SHF-140/2, SHFM-140, SHFM-140/2
		QS-180	SHF-180, SHF-180/2, SHFM-180, SHFM-180/2
		QSO-1080	SHF-290, SHF290/2, SHFM-290, SHFM-290/2
8	Chamber	-	-
9	Retaining nut	RN-001	Used on all Models
10	Sensor	254NM-HF	SHFM-140; SHFM-140/2; SHFM-180; SHFM-180/2; SHFM-290, SHFM-290/2
11	O-ring #2-369 EPDM	410631	SHF-290, SHF290/2, SHFM-290, SHFM-290/2

Section 3 Installation of UV Disinfection System

⚠ CAUTION



Electronic controller must be connected to a Ground Fault Protected Circuit (GFCI) receptacle and the lamp connector ground wire must be connected to the stainless steel chamber.

Before installing the system,

- Connecting pipes to the UV system should be supported, to avoid any undue strain on the UV chamber.
Note: *The UV system should not bear any load of the attached piping.*
- Avoid vibration from close proximity to heavy equipment or from erratic pumps (Vibrations from other equipment and/or water hammer can cause damage to UV lamps within the UV chamber).
- Allow sufficient service access clearance for the unit. Also, when preparing the site for installation, allow for valves, drain and bypass as part of your plumbing circuit.

The disinfection system is designed to be mounted horizontally within the main plumbing lines.

- The enclosure should be mounted either above or beside the reactor chamber. Never mount vertically with AC connector at top of controller to prevent moisture from running down cordage and causing a potential fire hazard. Drip loops in all cordage connected to controller is highly recommended.
- The complete water system, including any pressure or hot water tanks, must be sterilized before start up by flushing with chlorine (household bleach) to destroy any residual contamination. Refer to [Section 3.1](#).
- For safety purposes, the disinfection system must be connected to a GFCI.
- The disinfection system is intended for indoor use only. Do not install disinfection system where it may be exposed to the weather.
- A 5 Micron filtration must precede the disinfection system. Ideally, the disinfection system should be the last treatment the water receives before consumption.

Procedure:

1. [Figure 2](#) shows the installation of a typical disinfection system and the related components that may be used for the installation. The use of a by-pass assembly is recommended in case the system requires “off-line” maintenance. In this case, note the system requires supplementary disinfection for the distribution system if any water is used during by-pass condition. In addition, during by-pass, the water will NOT be disinfected and a “DO NOT CONSUME THE WATER” tag should be physically installed on the by-pass assembly until such time as the system is sanitized and returned to service. For more information, refer to our disinfection procedure, [Section 3.1](#). If the water is to be consumed while the system is off-line, the water must be boiled for two minutes prior to consumption.

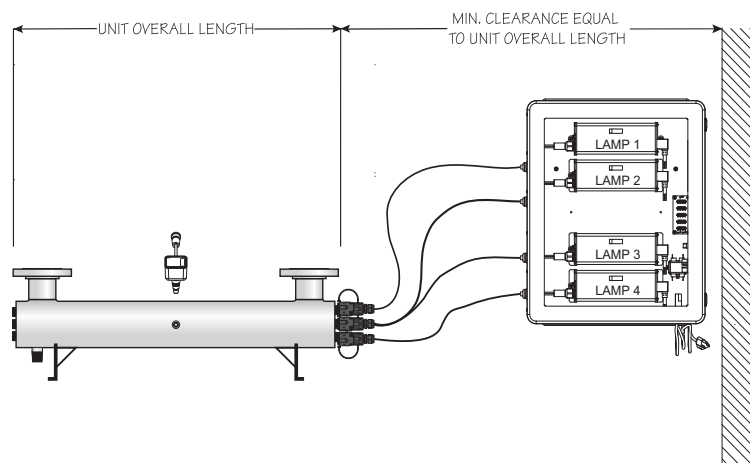

Figure 2 Disinfection System

2. Select a suitable location for the disinfection system and its related components. As it is recommended to install a GFCI, make sure that this is taken into consideration prior to any installation. The system must be installed horizontally, refer to [Figure 2](#). When selecting a mounting location, you must leave enough space to allow for the removal of the UV lamps and/or quartz sleeves (typically leave a space equal to the size of the reactor chamber itself).

Note: *Installation drawings show monitored system with UV sensor for representation purpose only.*

- Position a lifting strap around each of the UV Chamber mounting brackets (between the flange and the bracket). Center the lifting straps around the UV Chamber. Bring the two lifting straps above the UV Chamber and connect as required to a crane. Use a crane to lift the UV Chamber into position. The UV Chamber can be installed in either a horizontal or a vertical position.

Note: Avoid trapping air, ensure the outlet is oriented vertically.

- Install a flange gasket at the inlet and outlet flanges of the UV Chamber.
- Mount the system using the chamber mounting legs. Loosely install the flange mounting hardware (not provided) to the UV Chamber inlet and outlet flange to the plant piping. The provided mounting brackets on the UV Chamber can be mounted to pipe supports (by others) if available. Flange type connecting unions must be used to connect to the water source. The symmetric design of the chamber allows the water connections to the inlet and outlet ports to be interchangeable.

Note: The UV Chamber will not bear the load of process piping or other equipment. Make sure all piping is properly supported independent of the UV Chamber.

- Level the UV Chamber from front to back (horizontal), top to bottom (vertical).
- Secure the mounting hardware and torque adequately.
- Remove the lifting straps.
- Connect the UV Chamber drain to plant piping as required.
- Mount the Hi-Flo enclosure to the wall, near the reactor chamber. Ideally place the enclosure above the reactor and away from any water connection point, to prevent any water from potentially leaking onto the enclosure by means of a leak at a connection point or a “sweating” system. Make sure you allow for a “drip-loop” on the lamp, sensor and power cord, again, to prevent any water from potentially entering the enclosure. Affix the green ground wires to the grounding lug at the end of the reactor vessel and securely fasten with the lugnut provided [Figure 3](#).
- Install the UV lamps. Refer to [Section 4.1](#).
- When all plumbing connections are complete, slowly turn on the water supply and check for leaks. The most likely cause of leaks is from the O-ring seal. In case of a leak, shut water off, drain cell, remove the retaining nut, wipe the O-ring and threads. Clean and re-install.
- Once it is determined that there are no leaks, plug the system into the ground fault interrupter, and view the LED displays through the enclosure window to ensure the system is operating properly. The controller is designed to detect both power to the system and lamp illumination.
- It is important to NEVER LOOK DIRECTLY AT THE GLOWING UV LAMPS.
- Allow the water to run for a few minutes to clear any air or dust that may be in the chamber.

Note: When there is no flow, the water in the chamber will become warm, as the UV lamps are always on. To remedy this, run a cold water tap anywhere in the facility to flush out the warm water.

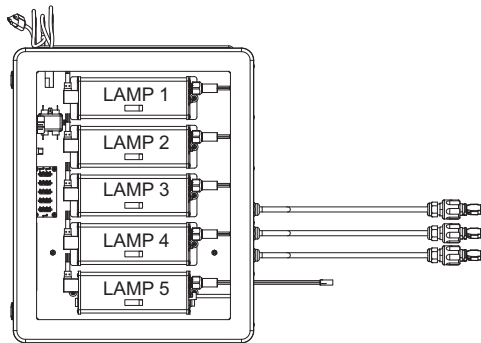

SHF-290 Control Panel shown

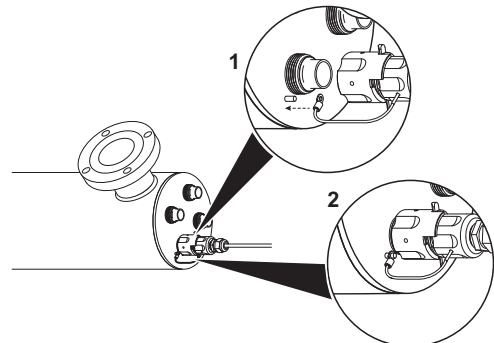

Figure 3 Ground Cable Connection

3.1 Disinfection Procedure

UV disinfection is a physical disinfection process and does not add any potentially harmful chemicals to the water. As UV does not provide a disinfection residual, it is strongly recommended that the entire distribution system located after the UV be chemically disinfected to ensure that the pipework is free from any bacteriological contaminants. The disinfection process should be performed immediately after the UV unit is installed and repeated thereafter whenever the UV is shut down for service, without power, or inoperative for any reason.

Section 4 Maintenance

⚠ WARNING



- Always disconnect power before performing any work on the disinfection system.
- Always shut-off water flow and release water pressure before servicing.
- Regularly inspect your disinfection system to ensure that the power indicators are on and no alarms are present.
- Replace the UV lamp annually (or biennially if seasonal home use) to ensure maximum disinfection.
- Always drain the chamber when closing a seasonal home or leaving the unit in an area subject to freezing temperatures.
- During extended periods of no water flow, the water in your chamber can become very hot (Approx. 60° C) and potentially lead to scalding. It is recommended to run your water until this hot water has been purged from your chamber. Do not allow water to contact your skin during this time. To eliminate this condition, a temperature management valve can be installed at the outlet of your UV system.

4.1 Replacing UV Lamp

NOTICE

- Reset UV lamp life timer after UV lamp replacement. Refer to [Section 5.1.3](#). Refer to www.lamprecycle.org for UV lamp disposal.
- Do not use water during replacement of UV lamp.

Lamp replacement is a quick and simple procedure requiring no special tools. The UV lamp must be replaced after 9000 hours of continuous operation (approximately one year) in order to ensure adequate disinfection.

Procedure:

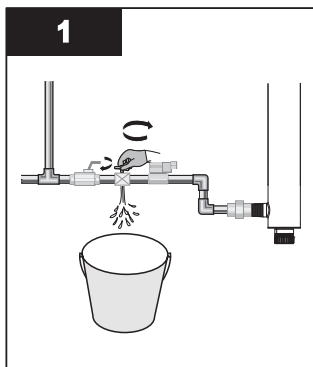

- Shut off the water line to chamber and release system pressure before servicing.
- Close all faucets.

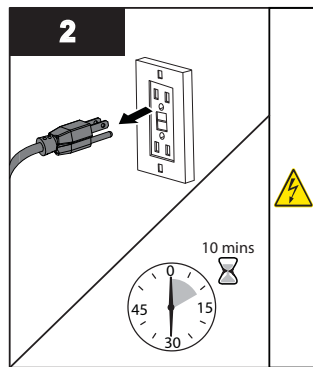

- Disconnect main power source and allow the unit to cool for 10 minutes.

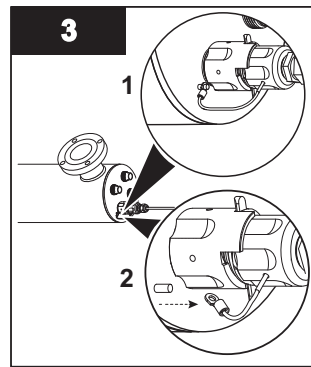

- Disconnect the ground cable.

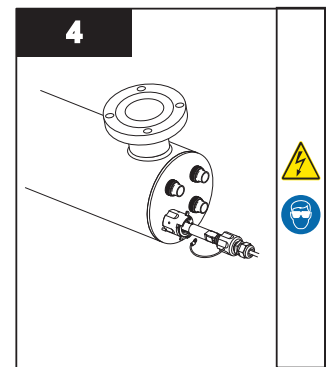

- Push down on the retaining clip and turn to unlock the lamp connector.
- Pull the lamp connector along with the UV lamp from the sleeve nut.

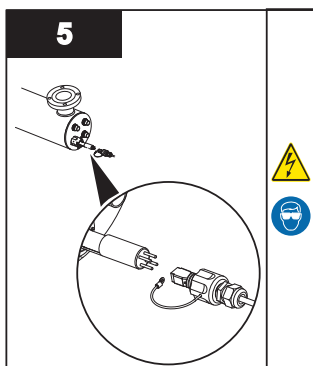

- Disconnect the lamp connector from the UV lamp.

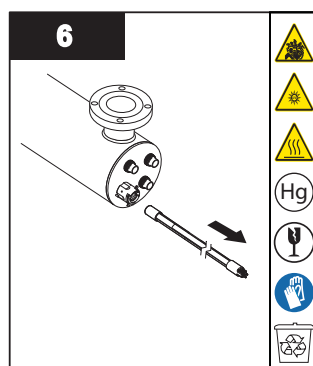

- Remove the UV lamp without twisting and discard the lamp.
- Note:** Always hold the UV lamp at the ceramic ends.

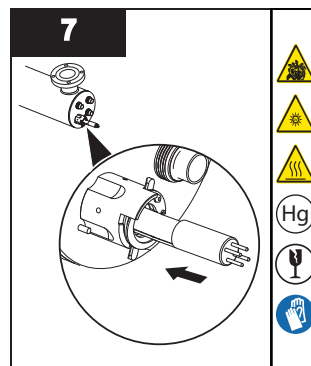

- Insert the new lamp fully into the sleeve leaving about two inches of the lamp protruding from the chamber.

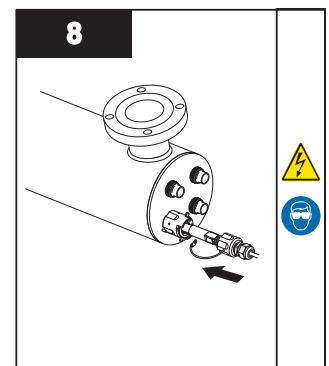

- Connect the lamp connector to the UV lamp.

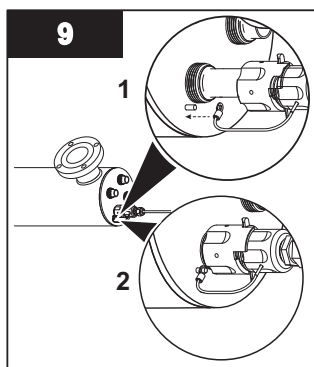

- Slide the lamp connector up to the sleeve nut.
- Push down on the retaining clip and turn to lock the lamp connector in place.
- Connect the ground cable and restore power.

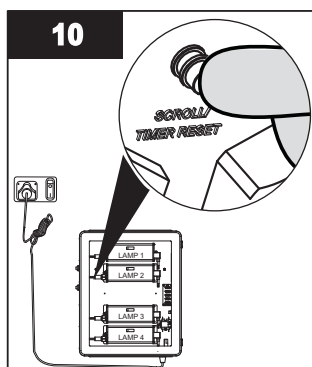

- Hold down the timer reset button and reapply power to the controller until you see [5EE], then release timer reset button.
- A 5 second delay will occur until you hear an audible tone and LED display will read once again [355].

Note: For lamp 1 replacement, it must be ensured that the lamp wires do not interfere with the UV sensor detection, as low UV alarms could result in Hi-Flo Monitored systems. The two wires should be oriented furthest away from the sensor port. Ensure the connector is fully seated onto the UV lamp.

4.2 Cleaning and Replacing Quartz Sleeve

Note: Minerals in the water slowly form a coating on the quartz sleeve. This coating must be removed because it reduces the amount of UV light reaching the water, thereby reducing disinfection performance. If the sleeve can not be cleaned, it must be replaced.

Prerequisites:

- Shut off water supply and drain all lines.
- Depressurize the unit. Place a small pail near the openings to catch any spills.
- Remove the UV lamp. Refer to [Section 4.1](#).

Procedure:

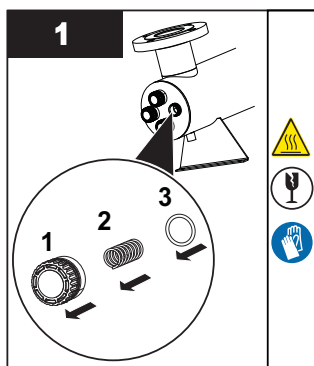

- Remove the sleeve nut, spring and O-ring.

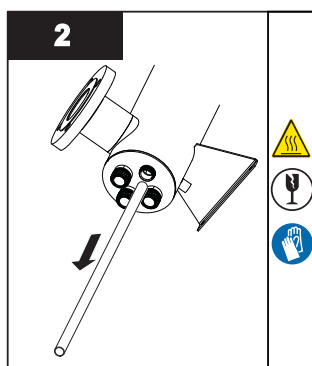

- Carefully, remove the quartz sleeve and second O-ring from the other end.

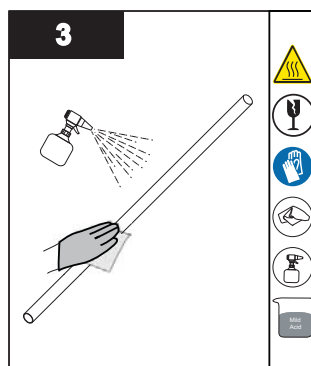

- Clean the quartz sleeve with a cloth soaked in CLR, vinegar or some other mild acid and then rinse with water.

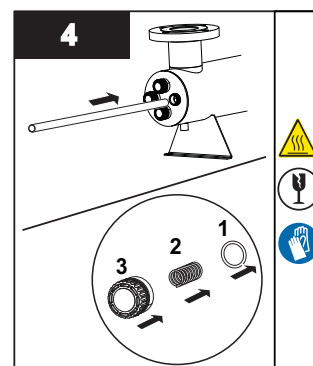

- Reinstall the quartz sleeve with lubricated O-rings, followed by O-ring, spring and sleeve nut.
- When service is complete, assemble the prerequisites in the reverse order of disassembly.

Notes: 1) After replacing the UV lamp or quartz sleeve perform the disinfection procedure, refer to [Section 3.1](#).

2) If the system is put on a temporary by-pass or if it becomes contaminated after the disinfection system, it is necessary to shock the system with household bleach for a full 20 minutes before resuming the use of the water.

4.3 Cleaning and Replacing UV Sensor (SHFM models only)

⚠ WARNING



The UV sensor is very delicate instrument. Extreme care is required when handling and cleaning. The sensor window itself is constructed from quartz which is extremely fragile, be careful you do not chip or break this quartz window. Manufacturer's warranty does not cover damage due to neglect or misuse.

Mineral deposits and sediment may accumulate on the sensor window decreasing the UV energy detected. Good maintenance of pre-treatment equipment will reduce the accumulation of residues. If the system indicates that the UV intensity is low, one cause may be a stained quartz sleeve and/or sensor window.

Prerequisites:

- Remove and clean the quartz sleeve.

Note: The quartz sleeve and UV sensor should be cleaned at the same time.

Procedure:

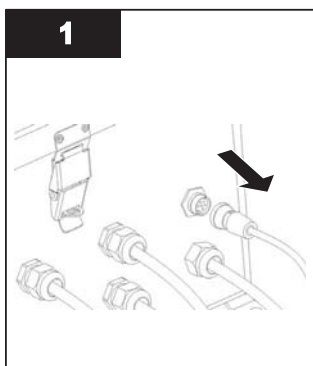

- Disconnect the UV sensor from the controller by disconnecting the sensor cable.

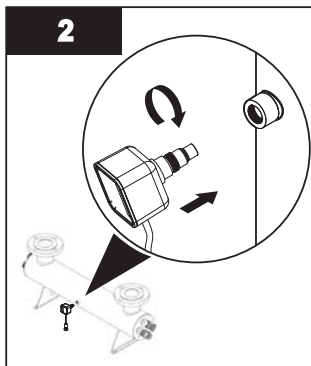

- Remove the UV sensor and O-ring by grasping the body of the sensor and rotating it counter-clockwise.

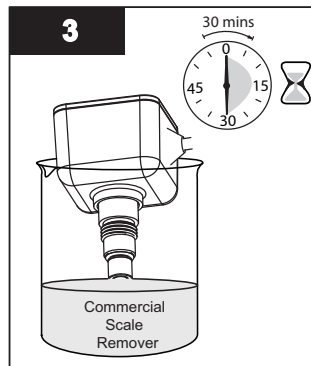

- Submerge only the end of the sensor in the commercial scale remover for 30 minutes.

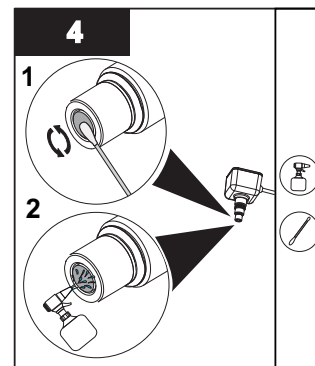

- Clean the sensor with a cotton swab and spray with water.
- Re-insert the UV sensor along with the O-ring until a water-tight seal is achieved.

Section 5 Operation

⚠ WARNING



The advanced warning system has been installed to provide the optimum protection against microbiological contamination in water. **DO NOT** disregard the warning signals. The best way to ensure optimum UV performance is to have the water microbiologically tested by a recognized testing agency on a regular basis.

5.1 Systems Incorporating BA-ICE-HF Controller

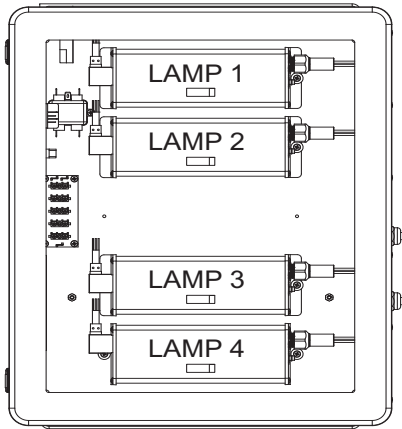

SHF-140/180 series control panel

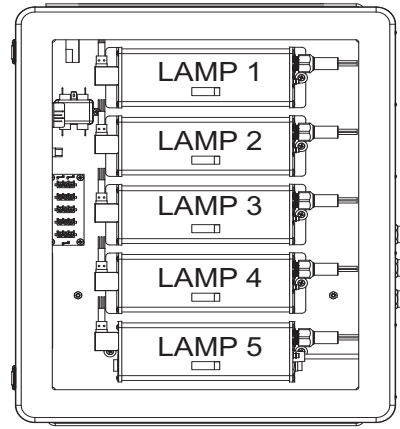

SHF-290 series control panel

5.1.1 Lamp Life Remaining (days)

365 The controller tracks the number of days of operation of the lamp and the controller. The default screen will display the total lamp life remaining (in days). The controller will count down the number of days remaining until the lamp requires changing (365 days to 1 day). At “0” days, the controller will display **A3** on the display and supply an intermittent audible chirp (1 second on, 5 seconds off), indicating the need to change the lamp.

5.1.2 Understanding your “A3” Code

A3 DEFERRAL - Once the “A3” or end of lamp life message is shown on the LED screen, the audible alarm can be deferred up to 4 separate times. The delay is designed to allow you time to address the alarm while you obtain a new UV lamp. This can be done by simply depressing the timer reset button for 5 seconds, which is located on the left side of the controller. Each time the timer reset button is pressed the controller alarm is deferred seven days. Once the final 7 day deferral has been reached the alarm can only be silenced by changing the UV lamp and manually resetting the controller timer, refer to [Section 4.1](#).

5.1.3 Resetting Lamp Life

Refer to [Section 4.1](#).

Note: Even though the alarm on the system can be deferred for a period of time, it is important to address each and every alarm condition as they are indicating that there is a potential problem with the system and should be remedied.

5.1.4 Total Days of Operation

1680 The controller also displays the total running time of the controller. To obtain this reading, press the push-button once. The total running time of the controller will be numerically displayed **1680** in days. This information will remain displayed for ten seconds and will then revert back to the lamp life remaining default screen. It should be noted that this value cannot be reset.

5.1.5 Lamp Failure (Blank Screen)

[Blank] When the system recognizes LAMP FAILURE (no current running through the lamp), the display will be blank (no **[Blank]** default LAMP LIFE REMAINING screen) and the system will supply an intermittent audible tone (1 second on, 1 second off). The system will remain in this state, until this condition is remedied.

5.2 “Plus” Systems Incorporating BA-ICE-M-HF Controller

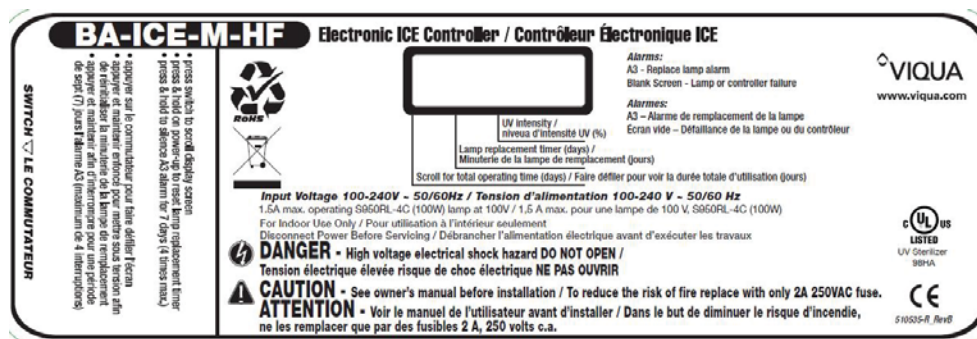

5.2.1 UV Intensity (%)

99 The Hi-Flo Monitored series incorporate a UV sensor which detects the discrete 254 nm wavelength of the UV lamp. This information is relayed to the VIQUA controller and is the default display shown in “% UV output”. The system will display the UV output between 50 to 99 percent. When the system drops below 50%, a low UV warning is displayed as R2 and alternately flashes (at 2 second intervals) back to the actual UV level. Eg. 49. Additionally, the system will supply an intermittent audible tone (2 seconds on, 2 seconds off), during low UV conditions.

Note: UV levels of

- 85 to 99 Indicates the system is functioning within a normal operating range.
- 56 to 84 Indicates the UV level is still within a safe level, however cleaning or lamp/sleeve replacement may soon be required.
- 50 to 55 Indicates the UV level is nearing the point of unsafe UV intensity, UV system should be immediately serviced.
- < 49 Indicates the UV level has now reached a level that is unsafe. At this level the water should not be consumed. The system/water supply should be examined to determine the reason for the low UV level of the UV intensity. At this level, the solenoid output has been activated and if a solenoid is installed, water will cease to flow.

DEFERRAL - To temporarily defer the audible alarm and re-activate solenoid valve (if fitted) during a low UV alarm, press the timer reset button and hold for five seconds. This will mute the audible alarm condition and activate solenoid output for 12 hours.

Possible causes for low UV alarm conditions:

- a. The UV lamp has perhaps reached a level whereby it can no longer adequately provide a sufficient level of disinfection due to age (> 9000 hours). The lamp should be replaced with a new lamp from the manufacturer of the same size and type.
- b. The quartz sleeve and/or the sensor window have become stained or dirty. Mineral deposits or sediment in the water that was not detected during the original water analysis may be the cause for this. Refer to [Section 4.3](#).
- c. Intermittent voltage drop in the household controller reducing the lamp output. The lamp will return to normal when the power is restored to full voltage.

Note: The monitoring system will not operate during power failures.

- d. The quality of the influent water has changed and is no longer within the acceptable operational range of the UV system. Perform a water analysis to determine the exact constituents and concentration levels.
- e. The UV sensor is not installed correctly.

5.2.2 Lamp Life Remaining (Days)

365 To obtain this reading, press the timer reset button a single time. Refer to [Section 5.1.1](#), Lamp Life Remaining.

5.2.3 Total Days of Operation

1680 To obtain this reading, press the timer reset button two times in succession. Refer to [Section 5.1.4](#), Total Days of Operation.

5.2.4 Lamp Failure (Blank Screen)

Refer to [Section 5.1.5](#) for explanation of this feature.

Note: On the VIQUA systems, the audible tone provided for lamp failure is a continuous alarm, rather than the intermittent (1 second on, 1 second off) condition on the basic VIQUA systems.

5.2.5 Solenoid Output

Please contact VIQUA Technical Support for assistance with solenoid valves.

5.2.6 4-20mA Output (Optional)

To achieve the capability to transmit the UV intensity data to a remote location via a 4-20 mA signal, use an optional “Y” cable (PN 260134) is available from your dealer. The “Y” cable comes with 20 meters (65’) of cable for the 4-20 mA signal.

Procedure:

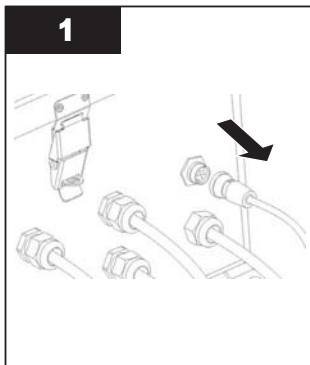

- Disconnect the existing sensor cable from the controller.

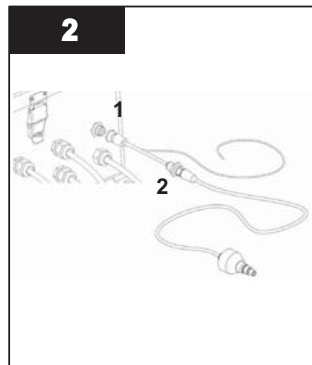

- Connect the ‘Y’ cable to the controller.
- Attach the “male” end of the removed sensor cable to the “female” end of the new “Y” cable.
- Appropriately attach the 4-20 mA cable to the applicable equipment and ensure all connections are hand-tight.

Section 6 Troubleshooting

Symptom	Possible Cause	Possible Solution
Pressure Drop	Sediment pre-filter clogged	Service pre-filtration Note: Check source water supply as fluctuations may occur in source pressure
High Bacteria Counts	Quartz sleeves are stained or dirty	Clean sleeves with scale cleaner and eliminate source of staining problem (i.e, soften hard water, refer to Section 4.3)
	Change in feed water quality	Have source water tested to ensure that water quality is still within allowable limits for this system
	Contamination in water lines after UV system (e.g. from power failures, plumbing, dead-ends, etc)	Shock with chlorine (bleach) downstream of UV system - disinfection system must have a bacterial free distribution system to work effectively
	Possible break-through of sediment through pre-filter	Have source water tested for turbidity - may need stepped filtration in order to catch all sediment entering water system (20 micron filter followed by a 5 micron filter followed by UV system)
Heated Product Water	Common problem caused by infrequent use of water	<ul style="list-style-type: none"> Run water until it returns to ambient temperature Install temperature management valve
Water Appears Milky	Caused by air in the water lines	Run water until air is purged
Unit Leaking Water	Problem with O-ring seal (on retaining nut, UV sensor and/or chamber end plates)	Ensure o-ring is in place, check for cuts or abrasions, clean o-ring, moisten with water/ lubricant and re-install, replace if necessary
	Condensation on reactor chamber caused by excessive humidity & cold water	Check location of disinfection system and control humidity
	Inadequate inlet/outlet port connections	Ensure flange seals are correct and not deteriorated. Clean and re-install. If leaks persist, replace flanges/seals
System Shutting Down Intermittently	Interrupted controller	Ensure system has been installed on its own circuit, as other equipment may be drawing power away from UV
Lamp failure alarm is on (blank display)	Loose connection between lamps and connectors	Disconnect lamps from connector and reconnect, ensuring that a tight fit is accomplished
	Moisture build up in connectors may keep lamp and connectors from making a solid connection	Eliminate chance of any moisture getting to the connectors and/or lamp pins

DISPLAY FAULT MODES

LED display reads "A3"	<ul style="list-style-type: none"> Lamp life expired - countdown is at "0" days. Refer to Section 5.1.2. Press reset button for a deferred alarm, replace UV lamp.
LED display is blank	<ul style="list-style-type: none"> Controller is in lamp failure mode. Refer to Section 5.1.5. Power system down, allowing it to reset itself; apply power in order to confirm that the controller is able to power lamp. Check to see if there is sufficient power to the UV system. Replace lamps.
Low UV level displayed on screen	<ul style="list-style-type: none"> Test water supply to see if water quality meets recommended parameter limits. Clean quartz sleeves and sensor eye.
LED flashing "A2" and then back to UV level	<ul style="list-style-type: none"> Low UV alarm deferral has been activated. Refer to Section 5.2.1. UV level has dropped below 50% and the audible alarm has been muted by pressing the reset switch and holding it for 5 seconds. This audible alarm deferral will only last 12 hours.

Section 7 Hi-Flo Series Dose Chart

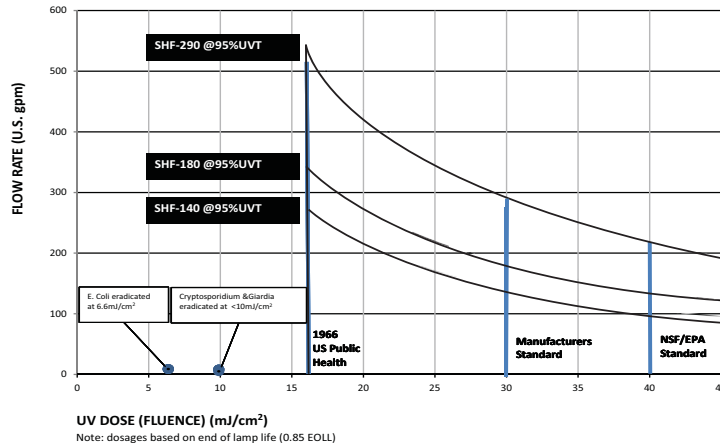

Section 8 Specifications

Model		SHF-140, SHF-140/2	SHFM-140, SHFM-140/2	SHF-180, SHF-180/2	SHFM-180, SHFM-180/2	SHF-290, SHF-290/2	SHFM-290, SHFM-290/2
Flow Rate	US Public Health 16mJ/cm ² @ 95% UVT	267.9 gpm (1014.2 lpm) (60.8 m ³ /hr)	267.9 gpm (1014.2 lpm) (60.8 m ³ /hr)	343.0 gpm (1298.3 lpm) (77.9 m ³ /hr)	343.0 gpm (1298.3 lpm) (77.9 m ³ /hr)	543 gpm (2055.5 lpm) (123 m ³ /hr)	543 gpm (2055.5 lpm) (123 m ³ /hr)
	VIQUA Standard 30mJ/cm ² @ 95% UVT	142.9 gpm (540.9 lpm) (32.5 m ³ /hr)	142.9 gpm (540.9 lpm) (32.5 m ³ /hr)	182.9 gpm (692.5 lpm) (41.5 m ³ /hr)	182.9 gpm (692.5 lpm) (41.5 m ³ /hr)	290 gpm (1097.8 lpm) 65 m ³ /hr	290 gpm (1097.8 lpm) 65 m ³ /hr
	NSF/EPA 40mJ/cm ² @ 95% UVT	107.2 gpm (405.7 lpm) (24.3 m ³ /hr)	107.2 gpm (405.7 lpm) (24.3 m ³ /hr)	137.2 gpm (519.3 lpm) (31.2 m ³ /hr)	137.2 gpm (519.3 lpm) (31.2 m ³ /hr)	215 gpm (813.8 lpm) 48 m ³ /hr	215 gpm (813.8 lpm) 48 m ³ /hr
Dimensions	Chamber	86.4cm x 15.2cm x 35.6cm (34" x 6" x 14")	86.4cm x 15.2cm x 35.6cm (34" x 6" x 14")	107.3cm x 15.2cm x 35.6cm (42.25" x 6" x 14")	107.3cm x 15.2cm x 35.6cm (42.25" x 6" x 14")	108 cm x 20.3 cm x 43.5 cm (42.5" x 8" x 17")	108 cm x 20.3 cm x 43.5 cm (42.5" x 8" x 17")
	Controller	44.9cm x 55cm x 22.4cm (17.7" x 21.7" x 8.8")					
Inlet/Outlet Port Size		3" Standard Flange Inlet and Outlet Ports	3" Standard Flange Inlet and Outlet Ports	3" Standard Flange Inlet and Outlet Ports	3" Standard Flange Inlet and Outlet Ports	4" Flange	4" Flange
Weight	Chamber	39 lbs (17.7 kg)	39 lbs (17.7 kg)	41 lbs (18.6 kg)	41 lbs (18.6 kg)	100 lbs (45.4 kg)	100 lbs (45.4 kg)
	Controller	38.5 lbs (17.5 kg)	38.5 lbs (17.5 kg)	38.5 lbs (17.5 kg)	38.5 lbs (17.5 kg)	41 lbs (18.6 kg)	41 lbs (18.6 kg)
Electrical	Voltage ¹	120-140 V / 50/60 Hz	120-140 V / 50/60 Hz	120-140 V / 50/60 Hz	120-140 V / 50/60 Hz	120-140V / 50-60 Hz	120-140V / 50-60 Hz
	Max. Current (120V Series)	3.5 Amp	4.0 Amp	4.5 Amp	5.0 Amp	5.0 Amp	6.0 Amp
	Max. Current (230V Series)	1.75 Amp	3.0 Amp	2.3 Amp	3.5 Amp	3.0 Amp	4.5 Amp
	Power Consumption	350 W	350 W	440 W	440 W	550 W	550 W
	Lamp Watts	300 W	300 W	380 W	380 W	380 W	380 W
Maximum Operating Pressure		125 psi (861 kPa)	125 psi (861 kPa)	125 psi (861 kPa)	125 psi (861 kPa)	125 psi (861 kPa)	125 psi (861 kPa)
Minimum Operating Pressure		15 psi (103 kPa)	15 psi (103 kPa)	15 psi (103 kPa)	15 psi (103 kPa)	15 psi (103 kPa)	15 psi (103 kPa)
Ambient Water Temperature		2-40 °C (36-104 °F)	2-40 °C (36-104 °F)	2-40 °C (36-104 °F)	2-40 °C (36-104 °F)	2-40°C (36-104°F)	2-40°C (36-104°F)
Lamp Type		High-output	High-output	High-output	High-output	High-output	High-output
Chamber Material		316 SS	316 SS	316 SS	316 SS	316SS	316SS

¹Units ending in "/2" are for 200-240VAC applications.

Section 9 Manufacturer's Warranty

Our Commitment

VIQUA is committed to ensuring your experience with our products and organization exceeds your expectations. We have manufactured your UV disinfection system to the highest quality standards and value you as our customer. Should you need any support, or have questions about your system, please contact our Technical Support team at 1.800.265.7246 or technicalsupport@viqua.com and we will be happy to assist you. We sincerely hope you enjoy the benefits of clean, safe drinking water after the installation of your VIQUA disinfection system.

How to Make a Warranty Claim

Note: *To maximize the disinfection performance and reliability of your VIQUA product, the system must be properly sized, installed and maintained. Guidance on the necessary water quality parameters and maintenance requirements can be found in your Owner's Manual.*

In the event that repair or replacement of parts covered by this warranty are required, the process will be handled by your dealer. If you are unsure whether an equipment problem or failure is covered by warranty, contact our Technical Support team at 1.800.265.7246 or e-mail technicalsupport@viqua.com. Our fully trained technicians will help you troubleshoot the problem and identify a solution. Please have available the model number (system type), the date of purchase, the name of the dealer from whom you purchased your VIQUA product ("the source dealer"), as well as a description of the problem you are experiencing. To establish proof of purchase when making a warranty claim, you will either need your original invoice, or have previously completed and returned your product registration card via mail or online.

Specific Warranty Coverage

Warranty coverage is specific to the VIQUA range of products. Warranty coverage is subject to the conditions and limitations outlined under "[General Conditions and Limitations](#)".

Ten-Year Limited Warranty for VIQUA UV Chamber

VIQUA warrants the UV chamber on the VIQUA product to be free from defects in material and workmanship for a period of ten (10) years from the date of purchase. During this time, VIQUA will repair or replace, at its option, any defective VIQUA UV chamber. Please return the defective part to your dealer who will process your claim.

Three-Year Limited Warranty for Electrical and Hardware Components

VIQUA warrants the electrical (controller) and hardware components to be free from defects in material and workmanship for a period of three (3) years from the date of purchase. During this time, VIQUA will repair or replace, at its option, any defective parts covered by the warranty. Please return the defective part to your dealer who will process your claim.

One-Year Limited Warranty for Lamps, Sleeves, and UV Sensors

VIQUA warrants lamps, sleeves, and UV sensors to be free from defects in material and workmanship for a period of one (1) year from the date of purchase. During this time, VIQUA will repair or replace, at its option, any defective parts covered by the warranty. Your dealer will process your claim and advise whether the defective item needs to be returned for failure analysis.

Note: *Use only genuine VIQUA replacement lamps and sleeves in your system. Failure to do so may seriously compromise disinfection performance and affect warranty coverage.*

General Conditions and Limitations

None of the above warranties cover damage caused by improper use or maintenance, accidents, acts of God or minor scratches or imperfections that do not materially impair the operation of the product. The warranties also do not cover products that are not installed as outlined in the applicable Owner's Manual.

Parts repaired or replaced under these warranties will be covered under warranty up to the end of the warranty period applicable to the original part.

The above warranties do not include the cost of shipping and handling of returned items.

The limited warranties described above are the only warranties applicable to the VIQUA range of products. These limited warranties outline the exclusive remedy for all claims based on a failure of or defect in any of these products, whether the claim is based on contract, tort (including negligence), strict liability or otherwise. These warranties are in lieu of all other warranties whether written, oral, implied or statutory. Without limitation, no warranty of merchantability or of fitness for a particular purpose shall apply to any of these products.

VIQUA does not assume any liability for personal injury or property damage caused by the use or misuse of any of the above products. VIQUA shall not in any event be liable for special, incidental, indirect or consequential damages. VIQUA's liability shall, in all instances, be limited to repair or replacement of the defective product or part and this liability will terminate upon expiration of the applicable warranty period.



425 Clair Rd. W, Guelph, Ontario, Canada N1L 1R1
t. (+1) 519.763.1032 • tf. (+1) 800.265.7246 (US and Canada only)
t. (+31) 73 747 0144 (Europe only) • f. (+1) 519.763.5069
e-mail: info@viqua.com
www.viqua.com