

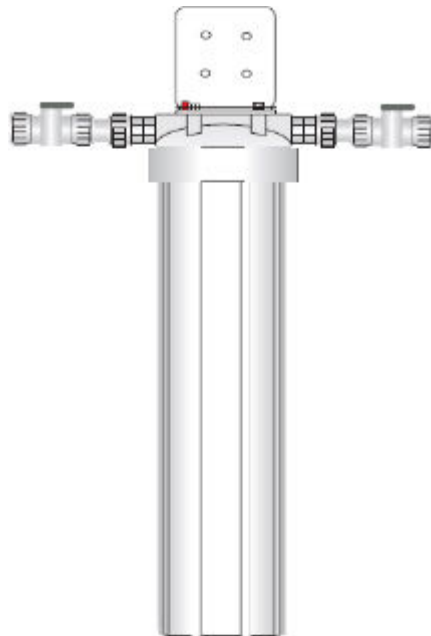

ecoTAC™ Protector 6

**Hard Water Mineral Scale Protection for
Water Heaters, Dish Washers, and
Other Low Flow Rate Applications**

OWNER'S MANUAL & INSTALLATION GUIDE



**PLEASE READ THIS MANUAL CAREFULLY BEFORE ATTEMPTING
INSTALLATION. FAILURE TO FOLLOW THESE INSTRUCTIONS MAY VOID
YOUR WARRANTY, CAUSE INJURY, OR RESULT IN PROPERTY DAMAGE.**

Congratulations on the purchase of your ecoTAC™ Salt-Free Hard Water Conditioner. You have purchased one of the finest hard water treatment systems on the market today. ecoTAC™ conditioners use the latest in salt-free hard water conditioning media technology to reduce or eliminate hard water mineral scale. ecoTAC™ is an environmentally-friendly alternative to conventional water softeners for preventing the formation of hard water scale in your plumbing system, water treatment equipment, water heater, dishwasher, and more.

This manual is designed to provide owners, installers, and service technicians with detailed information about the installation, start-up, and operation of your new water treatment system.

The heart of your ecoTAC™ system is its highly-specialized Template Assisted Crystalization (TAC) media. To ensure optimal performance and life of your TAC media, it is important that these instructions be followed and that the system is operated within the technical specifications provided. Your warranty may be voided if you fail to follow these instructions and/or fail to operate your treatment device within the guidelines noted.

Your ecoTAC™ water treatment system is designed to offer low maintenance operation. The ecoTAC filter cartridge will need to be replaced roughly every 2 years. As the TAC media is the most critical component to the success of your ecoTAC™ system, we strongly recommend that only authentic ecoTAC™ filter cartridges be used to replace your cartridges.

ecoTAC™ Protector 6 SPECIFICATIONS	
Housing Material:	Polypropylene
Filter Pressure Drop:	1 PSI at 6 Gallons Per Minute (0.1 bar at 23 LPM)
Maximum Recommended Flow Rate:	6 Gallons Per Minute (23 LPM)
Estimated Cartridge Life:	2 Years

All components are tested and certified against NSF/ANSI 61 for material requirements.

Table of Contents:

PACKAGE CONTENTS & PARTS LIST	3
OPERATING CONDITIONS	4
INSTALLATION	4
WHAT TO EXPECT IN THE FIRST FEW WEEKS	9
MAINTENANCE INFORMATION	10
WARRANTY	11

PACKAGE CONTENTS & PARTS LIST

- one (1) heavy-duty filter housing with 3/4" quick-connect fittings and pressure relief button
- one (1) mounting bracket and related screws (4)
- one (1) ecoTAC™ filter cartridge (shipped inside housing – remove protective wrap before using)
- one (1) spanner wrench
- two (2) 3/4" quick-connect shut-off valve assemblies

KEY COMPONENTS PARTS LIST:

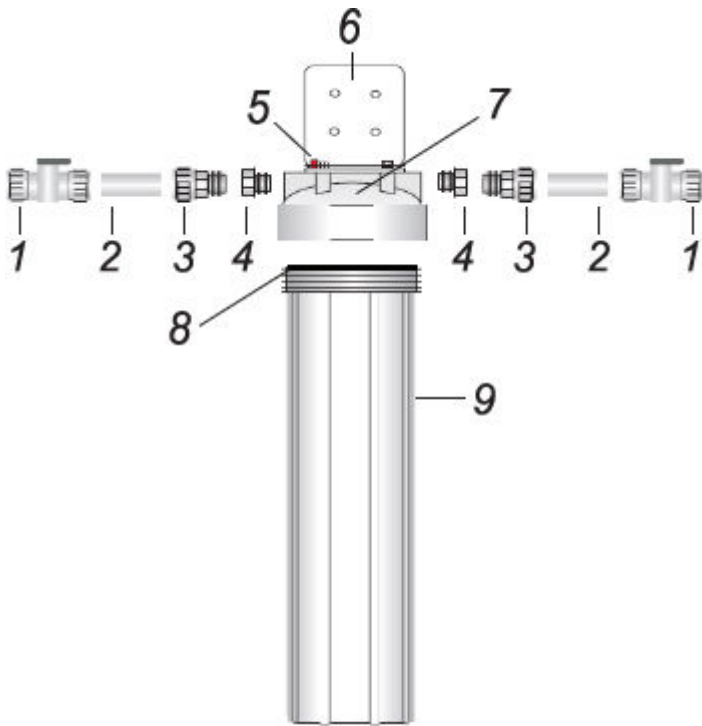

- | | |
|----|---|
| 1 | Quick Connect Shut-Off Valve (2) |
| 2 | 4" PEX Tube (2) |
| 3 | Quick Connect Fitting (2) |
| 4 | Reducing Bushing (2) |
| 5 | Pressure Relief Button (1) |
| 6 | Mounting Bracket (1) |
| 7 | Housing Cap (1) |
| 8 | O-ring (1) |
| 9 | Housing Sump (1) |
| 10 | Mounting Bracket Screws (4) – not shown |

OPERATING CONDITIONS

The following list provides guidance on the conditions required for successful operation of your ecoTAC™ system. Use of this equipment outside of these operating conditions may adversely affect the performance of your system, damage the TAC media, result in system damage including water leaks and resulting property damage, and may void your warranty.

It is very important to note that the presence of elevated levels of chlorine, iron, manganese, hydrogen sulfide, copper, and certain other contaminants can damage the TAC media, reducing its effectiveness and shortening its life. Use authentic ecoTAC™ pre-filters to remove these contaminants before your TAC filter. Chlorinated city water should generally be filtered through activated carbon to reduce chlorine prior to TAC treatment. **Water exceeding any of the following levels should be pre-treated to reduce contaminant levels below the stated level:**

Total hardness: <50 grains per gallon (850 ppm)
pH Range: 6.5 to 8.5
Chlorine: max. 3 ppm
Hydrogen peroxide: max. 0.5 ppm
Iron: max. 0.3 ppm
Manganese: max. 0.05 ppm
Copper: max. 1.3 ppm
Hydrogen Sulfide (H₂S), Polyphosphates, and Oils: must be removed

Maximum Water Temperature: 43C (110F)
Do not allow TAC media or the water in your ecoTAC™ system to freeze
Pressure Recommended: 15 to 80 psi

CONFIRM THAT YOUR WATER CONDITIONS MEET THE OPERATING CONDITIONS ABOVE BEFORE COMMENCING THE INSTALLATION PROCESS. IF IN DOUBT, CALL YOUR DEALER FOR ADVICE.

INSTALLATION

While we strongly recommend that a licensed plumber perform all installation work, a mechanically-inclined homeowner can install an ecoTAC™ system. In all cases, it is critical that the installation be done in accordance with these instructions and all applicable plumbing codes. Be sure to obtain all required permits. If these instructions and the applicable codes are in conflict, the relevant plumbing/electrical code shall be followed. Equipment failure, personal injury, or property damage can result if this equipment is not installed properly.

You will need the following plumbing supplies:

- The fittings on the ecoTAC™ system are designed to quick-connect (“push fit”) to 3/4” PEX, copper, or CPVC pipe. You will need a short piece of 3/4” PEX or CPVC pipe (see specs below) and a suitable union for each side of the housing (inlet and outlet) to connect to your pipe type and size. 2 short pieces of PEX are provided for your convenience. While copper may be used, it is not recommended for the reasons discussed later in this manual. Your plumber will have these items, or they can be purchased at your local hardware or plumbing supply store at minimal cost (take these instructions to the store with you so the store clerk can make sure you get everything you need). Only use galvanized fittings for installation on galvanized pipe.

For your convenience, your ecoTAC system includes quick-connect style fittings (3/4”) on the housing and the shut-off assemblies. These fittings are designed to connect to pipe/tubing certified to the following specifications:

PEX (ASTM F876, CSA B137.5)
 Copper (ASTM B88)
 CPVC (ASTM D2846, CSA B137.6)

STEP 1. Select an installation location. This product is intended for indoor installation only. This filter may be used to treat all of the water for an entire building if the flow rate is less than 6 gallons per minute, however, it is more commonly used to treat only the water going to a tankless water heater. How you plan to use this product will determine the location of installation. In any event, select an installation location with convenient access for regular filter replacements and maintenance. The ecoTAC™ conditioner is design to be installed after treatment for iron, manganese, hydrogen sulfide, sediment, and chlorine (if required). Polyphosphate feeders should never be placed before the ecoTAC™ conditioner.

If you plan on using this product to treat all of the water entering the building, this filter should be installed on the main **cold water line** after the pressure tank or water meter, and after most any other water treatment equipment except a UV sterilizer or chlorinator. The recommended sequence of water system/treatment equipment **if you are using this product to treat all of the water for the building** is as follows:

- Pressure Tank or Water Meter If Applicable
- Branch Line to Outdoor Irrigation
- Backwashing Iron Filter (if equipped)
- S10 Sediment Pre-Filter Package or Similar (if equipped)
- Fe6 Cartridge-Based Iron Reduction Filter (if equipped)
- C6 Activated Carbon Pre-Filter or Similar (if equipped)
- ecoTAC Salt-Free Hard Water Conditioner**
- UV Sterilizer or Chlorinator for Disinfection of Bacteria, Viruses, etc. (if equipped)

If you are using this product to treat just the water going to a specific application in the building (tankless water heater or dish washer for instance), it should be located on the branch water line prior to the appliance or equipment that you are seeking to protect from hard water scale, but after most

other water treatment equipment. If this filter is used after a chlorinator, you should install the C6 Activated Carbon Pre-Filter to protect the filter from excess chlorine which can harm the media.

STEP 2. Shut off the main water supply and drain the pipes. Opening the highest and lowest fixtures in the house will help drain the pipes. **WARNING. If you have an electric water heater (tankless or conventional), TURN OFF all power to the water heater before proceeding. If you fail to do this, you may cause severe permanent damage to its heating elements.**

STEP 3. Using a pipe cutter, cut out a section of your main water line at the point where you want to install your filter system. There will probably be some water remaining in the system, so be sure to have a bucket and some rags handy to clean up any small spills. Make sure that the section of water line you remove is appropriately sized such that all of the components of the system including the shut-off-valves, adapters, and the blue filter cap(s) will fit snugly when assembled. If in doubt, cut a smaller section at first – you can always remove a slightly larger section upon final assembly if necessary.

STEP 4.

It is now time to assemble the system. Your ecoTAC™ unit is supplied with quick-connect fittings for your convenience. These fittings do not require any tools or sealants (Teflon, etc.) These fittings connect by pushing the pipe into the fitting approximately 1 1/2" until it stops and turning the collar 1/4 turn clockwise to lock the fitting in place. An o-ring inside the fitting forms a tight seal on the pipe and teeth inside the fitting prevent the fitting from disconnecting under pressure.

In the event that the fitting ever needs to be removed, you simply turn the collar 1/4 turn counter-clockwise, depress the fitting insert squarely against the fitting to release the teeth, and pull out on the pipe.

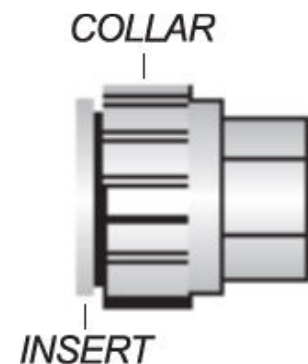

If you are installing a S10 sediment, C6 carbon, or Fe6 iron removal pre-filter with your ecoTAC™ unit, please go to Step 4B, otherwise continue with Step 4A.

STEP 4A. Assemble the components according to Diagram #1 below. Start by taking quick-connect shut-off valve assembly labeled "IN" and pushing it into the quick-connect fitting on the inlet side of the housing cap ("IN" is embossed on top of the white cap on the inlet side). Turn the collar on the quick-connect fitting clockwise roughly 1/4 turn to lock the fitting. Take the other quick-connect shut-off valve assembly labeled "OUT" and connect it to the quick-connect fitting on the opposite side of the housing cap and lock it into place in the same manner. Attach the mounting bracket to the housing cap using the 4 fasteners provided, then securely mount the housing to the wall using wood screws. If you are securing the system to drywall or plaster, be sure that the wood screws reach a wood stud, or alternatively, install appropriate anchors for secure support. Be sure to allow enough space below the housing cap to accommodate the white housing sump plus a minimum of an additional 3 inches of clearance.

Diagram #1

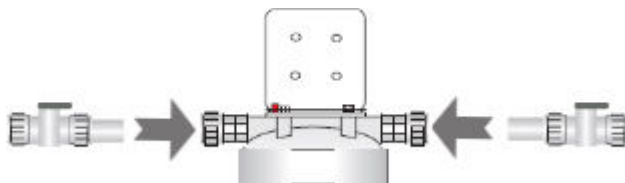

STEP 4B. Follow this step only if you are also installing a S10 sediment, C6 carbon, or Fe6 iron removal pre-filter(s) with your ecoTAC unit.

Assemble the components according to Diagram #2 below in the following sequence:

S10 Sediment Pre-Filter Package or Similar (if equipped)

Fe6 Cartridge-Based Iron Reduction Filter (if equipped)

C6 Activated Carbon Pre-Filter or Similar (if equipped)

ecoTAC Salt-Free Hard Water Conditioner

Start by taking the quick-connect shut-off valve assembly labeled “IN” and pushing it into the quick-connect fitting on the inlet side of the first housing cap (“IN” is embossed on top of the white cap on the inlet side). Turn the collar on the quick-connect fitting clockwise roughly 1/4 turn to lock the fitting. Connect this housing cap to the next housing in the sequence using the PEX tube from the pre-filter package in the same manner. Make sure that you are always connecting the outlet of one housing cap to the inlet of the other. Don’t forget to lock each fitting by turning the collar on the quick-connect fitting 1/4 turn. Repeat as necessary until all of the housing caps are connected. When you are done, check to be sure that the inlet and outlets of each housing are connected in the correct sequence. Finally, take the other quick-connect shut-off valve assembly labeled “OUT” and connect it to the quick-connect fitting on the opposite side of the last housing cap and lock it into place in the same manner.

Attach the mounting brackets to each housing cap using the 4 fasteners provided, then securely mount the housings to the wall using wood screws. Check to make sure the brackets are level. If you are securing the system to drywall or plaster, be sure that the wood screws reach a wood stud, or alternatively, install appropriate anchors for secure support. Be sure to allow enough space below the housing caps to accommodate the white housing sumps plus a minimum of an additional 3 inches of clearance.

Diagram #2

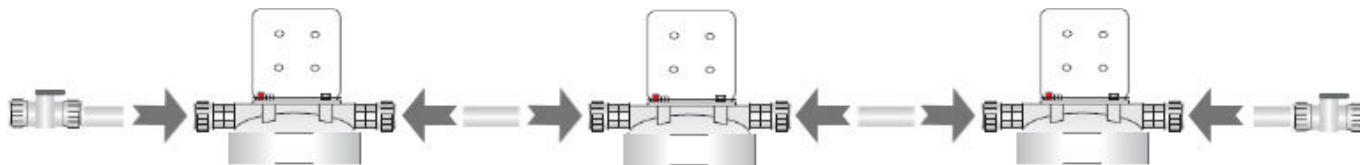

STEP 5. Make the appropriate plumbing connections between the inlet and outlet shut-off valves and your plumbing lines using appropriate union fittings where necessary. 3/4” PEX, Copper*, or CPVC tubing (see required specifications above) can be push fit to the shut-off valves on the inlet and outlet of the system in the same manner as the previous connections. *While copper can be used, it is not recommended.

IMPORTANT WARNINGS REGARDING PLUMBING CONNECTIONS TO THE SYSTEM:

Teflon tape should be used on all threaded fittings. Plumber's cement should NOT be used. If possible, we recommend that PEX or CPVC pipe be used for all new plumbing pipe used in connection with the installation. This is because new copper water lines may release some copper ions into the water for several weeks after installation and these ions can have a negative impact on the ecoTAC™ media. To further minimize any problems with copper, avoid applying excess flux on the inner surfaces of the pipe and use a low-corrosivity water soluble flux listed under the ASTM B813 standard. For homes with significant newly installed copper pipes prior to the ecoTAC™ unit, it is recommended that installation of the ecoTAC™ cartridge be postponed for 3-4 weeks to allow a protective coating to form on the new copper pipes.

If you wish to use copper piping and will be soldering the joints, DO NOT apply heat near your ecoTAC™ unit or connection fittings, or serious internal damage to these parts could occur. Always solder joints with these components detached.

Note: If your water pipes are metal (galvanized or copper), they may be used to ground electrical systems, appliances, or your phone line. If this is the case, be sure to install regulation ground clamps to the metal pipe on each side of the ecoTAC™ unit and connect a jumper wire between the 2 clamps (#4 gauge solid copper wire recommended). Consult a certified electrician or plumber if you are unsure.

If you suspect that your water pressure will at any time exceed the maximum rating of 90 PSI (6.2 bar), a pressure regulator must be installed before the system. It is recommended that the pressure regulator be set at 75 PSI (5.2 bar) or less.

STEP 6. Remove the protective plastic wrap from each filter cartridge and place it in the corresponding white housing sump. The wider part of the ecoTAC™ cartridge is the top. At the bottom of the sump, there is a raised portion in the middle (standpipe) that will help center the filter in the housing. The standpipe will fit inside the hole in the bottom of filter cartridge. Store any spare filters in a cool dry place for future use (do not unwrap the protective plastic wrap on your spare filters until you are ready to use them). Check to make sure that the O-ring is seated properly at the top of the housing sump. Screw the housing sump onto the housing cap. Use the spanner wrench to tighten. It is not necessary to over-tighten to create a good seal. Do not use excessive force.

STEP 7. Turn on the water and inspect all plumbing connections very carefully for leaks. Also inspect the seal between the housing cap and the housing sump to ensure that the O-ring has formed a good seal. Tighten this connection again using the spanner wrench if necessary. If this connection still leaks, turn off the water supply and check to make sure that the filter is aligned properly in the housing and repeat your test for leaks. When you are confident that all connections are sound, run cold water for 5 minutes at any faucet to purge air out of your system and to prime the filters. It is safe to turn on the power to your electric water heater again once all air is purged.

Important Notes:

1. The housing sump should be replaced every 10 years or if you notice any cracks or damage.
 2. This filter system should not be used with water that is microbiologically unsafe or of unknown quality without adequate disinfection before and/or after the system.
 3. Water filter systems should never be exposed to freezing temperatures - severe damage to the filter and housings could result. Such damage is not covered under any warranty.
 4. After prolonged periods of non-use (such as a vacation), it is recommended that the system be flushed thoroughly for at least 5-10 minutes before using the water.
-

WHAT TO EXPECT IN THE FIRST FEW WEEKS

During the first 1-6 weeks after the installation of the ecoTAC™ conditioner, a de-scaling effect whereby existing hard water scale previously built-up in the plumbing system is released, will often occur. Over time, this will enhance performance of water heating equipment and restore flow performance of plumbing fixtures. However, it may be necessary to clean out your faucet aerators and showerhead periodically during this time to remove pieces of scale that have dislodged from your pipes. This effect will stop once the pipes have been de-scaled.

After installation of ecoTAC™, low or phosphate-free cleaning products (for clothes and dishwashing) are recommended to achieve optimum results. Modern surfactant or detergent based, liquid soaps are preferred over old-fashioned caustic solid soaps.

Water heaters

Existing mineral accumulations in your water heater may also de-scale after the installation of ecoTAC™. If you have a traditional water heater, we recommend that you clean out this material by opening the bottom drain valve on the hot water heater 30 to 60 days after installation of ecoTAC™. Be sure to turn off the electricity or gas to your water heater before draining your tank. Follow the manufacturer's instructions for draining and flushing the tank. The good news is that a clean water heater uses much less electricity or gas to keep the water hot!

Dishwashers

To accelerate de-scaling in your dishwasher, you may wish to put a cup of white vinegar in the upper basket during the washing cycle for the first few weeks. You can also use citric acid or a commercial product like CLR or Lime Away instead of the white vinegar. This will help dissolve the existing scale in the washer arms and inside surface of the dishwasher. You may need to do this until all of the scale in the plumbing is dissolved. If you are using harsh dishwashing detergents that have low pH, high chlorine, and phosphates, some of the nano-crystals formed by the ecoTAC™ system may break down and cause spotting on the dishes. We recommend that you reduce your soap usage as much as 50%, and that you

use eco-friendly phosphate-free dishwashing detergents. Using an anti-spotting agent such as Jet-Dry® or Finish® may also be useful.

A word about glass shower doors...

Over a few weeks you may see the existing scale slowly dissolve in your shower heads thereby increasing water flow. You may need to clean the inlet screen of your shower head during the first few weeks as mentioned previously to remove some of the scale that is being removed from your pipes. We recommend that you first clean the shower of existing scale with a cleaning product that dissolves old scale that has built up before installation of the ecoTAC™ conditioner system. CLR or Lime Away are good cleaner choices for this purpose. We then recommend that you coat the walls in the shower, and your glass shower doors with Rainx, a commercial product used for automobile windshields. The Rainx allows the majority of the nano particles to be easily washed to drain. The few nano particles that are left can be easily wiped down because they can no longer adhere to the sides of the shower.

MAINTENANCE INFORMATION

The filter cartridge in your system will need to be replaced every 2 years or sooner if hard water scale is noticed. Use only genuine ecoTAC™ Cartridges for replacement. Use of an alternative media may adversely affect the performance of the system.

Replacement Filters can be Obtained From Your Dealer

Replacement Filter:

ecoTAC™ P6R Cartridge – replace every 24 months or if hard water scale returns

Filter Cartridge Replacement Procedure:

1. Turn off the water supply to the system using the shut-off valves you installed on the inlet and outlet of the filter housing(s). Depress the pressure release button on the top of each filter housing cap to allow any pressure inside the housing to escape. Using a regular slotted screwdriver, remove the brass drain plug from the bottom of each white housing sump to drain all of the water from the housings. Use a bucket to catch all of the water.
2. Unscrew housing sump from the cap using the spanner wrench (included with original purchase of your system).
3. Take out the old filter cartridge and discard it.
4. Scrub the bottom of the housing and cap with dish soap and warm water using a sponge or soft cloth. Fill 1/3 with water and add about 2 tablespoons of household bleach. Scrub to disinfect (we recommend that you use rubber gloves). **Rinse all parts thoroughly!**
5. Inspect large O-ring. The housing O-ring should be replaced at least once every 2 years or at each filter change if any damage to the O-ring is noted (kinked, cracked, stretched, etc.), or if any

leakage between the housing cap and the housing sump is detected and does not seal after tightening with the spanner wrench. Lubricate the O-ring with food-grade silicon lubricant if needed. DO NOT use petroleum jelly.

6. Remove the protective plastic wrapping from the new filter cartridge and insert the cartridge into the housing sump, making sure that it slips over the standpipe in the bottom of the housing. The wider part of the cartridge is the top.
7. Screw the sump onto the housing cap. Use the spanner wrench to tighten. It is not necessary to over-tighten to create a good seal. Do not use excessive force.
8. Turn on the water supply slowly to allow the system to fill with water. Depress the pressure release button on top of the unit again to release any trapped air. **Inspect carefully for leaks.** If a leak is found, first inspect the O-ring to ensure that it is seated properly before tightening the sump more. Tighten using the spanner wrench as necessary to achieve a good seal and stop leaks.
9. Flush the system by running water from a nearby faucet for 5 minutes prior to using the water.

WARRANTY

Your ecoTAC™ system components are warranted by HomePlus Products Inc. to be free of defects in material and workmanship for a period of one year from the date of purchase provided that your system was purchased from an Authorized dealer; operated in accordance with operating conditions stated herein; and provided that it was installed in accordance with these instructions.

This warranty applies only in Canada and the United States of America.

In the event that a part is deemed defective, the user must immediately inform HomePlus Products Inc. who will furnish a replacement part at no cost to the user.

This warranty does not cover shipping costs or any labour costs related to troubleshooting, installation or maintenance.

The warranty does not apply to the following situations: misuse; normal wear and tear; neglect; unauthorized repair or damage caused through installation, adaptation, modification; use in an improper manner or inconsistent with these operating and maintenance instructions; wear or deterioration due to environmental conditions; damage occurring during transit; mishandling; improper storage; incorrect supply of water; tampering or alteration; act of god; or any cause beyond the control of HomePlus Products Inc.

The original warranty period does not change in the event of part replacement by HomePlus Products Inc.

The warranty is issued exclusively to the original consumer purchaser of record and is not transferable. The provisions of the foregoing warranty are in lieu of any other warranty, whether express or implied, written or oral (including any warranty of merchantability or fitness for a particular purpose). HomePlus Product Inc.'s liability arising out of the manufacture, sale, or supplying of the products or their use or disposition, whether based upon warranty, contract, tort, or otherwise, shall not exceed the actual purchase price paid by the authorized distributor or consumer for the product. In no event shall HomePlus Products Inc. be liable to the distributor or any other person or entity for special, incidental, consequential or punitive damages (including, but not limited to, property loss, loss of incomes, or loss of use damages) arising out of the manufacture, sale, or supplying of the products, even if HomePlus Products Inc. has been advised of the possibility of such damages or losses.

HomePlus will not be liable under this warranty for any fault or damage arising from defective workmanship if the product has been modified by any person other than HomePlus Products Inc.

Proof of purchase is required for warranty service.

**To report a warranty problem with your system, please call HomePlus Products Inc.
Toll free: 1-866-376-2690**

MANUFACTURED BY:



HomePlus Products Inc.

**5-1490 Pearson Place
Kamloops, BC V1S 1J9
Canada**

Phone: 250-374-2690

Fax: 250-374-2692

www.homeplusproducts.com