

OWNER'S MANUAL & INSTALLATION GUIDE



made in the U.S.A.

ClearPlus MicroTurb™ Series Turbidity Reduction Filters w/ NextSand

highly effective and economical sediment / turbidity / particulate reduction filters with higher flow rates, lower backwash rates, and finer filtration than the competition!

**PLEASE READ THIS MANUAL CAREFULLY BEFORE ATTEMPTING
INSTALLATION. FAILURE TO FOLLOW THESE INSTRUCTIONS MAY VOID
YOUR WARRANTY, CAUSE INJURY, OR RESULT IN PROPERTY DAMAGE.**

Congratulations on the purchase of your MicroTurb™ Series turbidity filtration system. You have purchased one of the finest sediment/turbidity treatment systems on the market today. All MicroTurb™ Series water treatment systems utilize NextSand media, the world's most advanced turbidity reduction media. In addition to providing much finer filtration than traditional sand and multi-media filters, NextSand requires a lower backwash rate and volume and has higher service flow rates for a given volume of media. This manual is designed to provide owners, installers, and service technicians with detailed information about the installation, start-up, and operation of your new filter system.

The brain of your MicroTurb™ system is the Fleck 5800SXT control valve. It is manufactured by one of the world’s largest water treatment companies. The Fleck 5800 control valve is well respected for its reliability, serviceability, simple operation, and value. The integrated Fleck SXT digital valve controller offers unsurpassed simplicity of operation, yet complete control over all important valve operations. The Fleck 5800 and SXT controller service manuals are also included with your system.

Your MicroTurb™ water treatment system is designed to offer low maintenance operation. The control valve will perform regular backwash functions automatically. For your convenience, your system has been pre-programmed for you by our technicians. Should you need to change any of the settings, simply follow the instructions provided in this manual.

Table of Contents:

OPERATING CONDITIONS	3
INSTALLATION	4
Step 1 – Pre-Installation Inspection	4
Step 2 – Select an installation Site	5
Step 3 – Prepare Treatment Tank	5
Step 4 – Turn off the Water & Electric Water Heaters	7
Step 5 – Prepare and Install Inlet and Outlet Plumbing Connections...	8
Step 6 – Drain Line Installation	9
Step 7 – Control Valve Set-up	10
Step 8 – Initial Start-up and Leak Testing	12
BACKWASH	13
CHANGING TIME OF DAY	14
USER PROGRAMMING MODE	14
MASTER PROGRAMMING MODE	15
RESETS	16
CONTROL OPERATION DURING A POWER FAILURE	17
MAINTENANCE & TROUBLESHOOTING.....	17
WARRANTY INFORMATION	19

OPERATING CONDITIONS

The following chart provides guidance on the conditions required for successful operation of your MicroTurb™ system. Use of this equipment outside of these operating conditions may adversely affect the performance of your system, result in media clogging, result in system damage including water leaks and resulting property damage, and may void your warranty.

For optimal filtration, the service flow rate range should not be exceeded. Satisfactory filtration can generally be achieved up to the recommended peak flow rate as long as this level of flow rate is not sustained continuously.

	MicroTurb™ 7	MicroTurb™ 11	MicroTurb™ 15	MicroTurb™ Custom
Tank Size	8 x 44"	10 x 54"	12 x 52"	
Inlet / Outlet	3/4" NPT (1" optional)	3/4" NPT (1" optional)	1" NPT	
Media Used	NextSand	NextSand	NextSand	NextSand
Media Volume	0.8 CF	1.6 CF	2.3 CF	
Maximum Water Pressure	70 PSI*	70 PSI*	70 PSI*	70 PSI*
Minimum Water Pressure	30 PSI	30 PSI	30 PSI	30 PSI
Optimal Water Pressure	40-65 PSI	40-65 PSI	40-65 PSI	40-65 PSI
Maximum Water Temperature	110°F (43°C)	110°F (43°C)	110°F (43°C)	110°F (43°C)
Minimum Air Temperature	32°F (0°C)**	32°F (0°C)**	32°F (0°C)**	32°F (0°C)**
Max. (Peak) Flow Rate	7 GPM	11 GPM	15 GPM	
Service Flow Rate	Up to 6 GPM	Up to 8.7 GPM	Up to 12.5 GPM	
Backwash Flow Rate	5 GPM	8 GPM	12 GPM	
Backwash Frequency Default Setting***	Every 5 days, for 10 minutes	Every 5 days, for 10 minutes	Every 5 days, for 10 minutes	

* if your home water pressure is greater than 70 PSI, you should install a pressure reduction valve prior to installing this product.

** the unit cannot be subjected to freezing conditions or severe damage to the system and/or your property could occur.

*** using the SXT digital controller, both the frequency and duration can easily be adjusted to accommodate your water conditions.

CONFIRM THAT YOUR WATER CONDITIONS AND AVAILABLE BACKWASH FLOW RATE MEET THE ABOVE SPECIFICATIONS FOR THE MODEL YOU ARE INSTALLING BEFORE COMMENCING THE INSTALLATION PROCESS. IF IN DOUBT, CALL YOUR DEALER FOR ADVICE. INSTALLED UNITS CANNOT BE RETURNED.

INSTALLATION



We recommend that you read the entire instructions before commencing the actual installation. While we strongly recommend that a licensed plumber perform all installation work, a mechanically-inclined homeowner can install a MicroTurb™ system. In all cases, it is critical that the installation be done in accordance with these instructions and all applicable plumbing and electrical codes. Be sure to obtain all required permits. If these instructions and the applicable codes are in conflict, the relevant plumbing/electrical code shall be followed. Equipment failure, personal injury, or property damage can result if this equipment is not installed properly.

Step 1. – Pre-Installation Inspection

Inspect all of the components that you received with your unit. You should have received the following:

1. Fleck 5800 SXT Control Valve
2. Treatment Tank with Jacket Kit*
3. Fine Screen Upper Locking Stack Diffuser
4. Bypass Assembly
5. Riser tube and lower distributor
6. Bag or box of gravel
7. Bag or box of NextSand media
8. Funnel
9. Drain Line Flow Restrictor (attached to #1)

* tank jacket kits are included with all standard MicroTurb™ units and consist of a wrap-around grey / silver jacket and black cap. Tank jackets are optional on all custom MicroTurb™ systems and therefore might not be included with your unit.

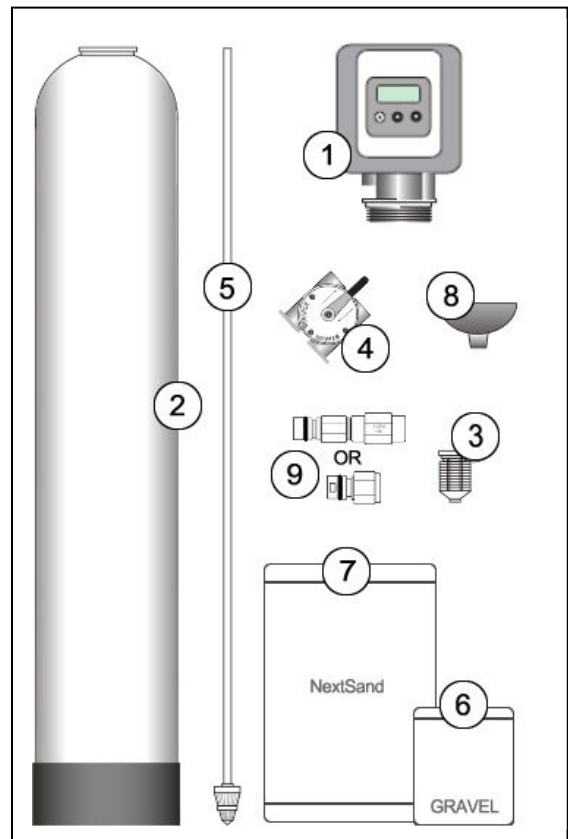

Step 2. – Selecting an Installation Location

We recommend interior installation only. The system cannot be allowed to freeze or severe system damage could occur. The system should not be installed in direct sunlight as long-term exposure to UV light could damage components of the system. Furthermore, direct sunlight could raise the internal water temperature in the treatment tank and reduce backwash effectiveness. In most cases, the system should be located AFTER the expansion tank and BEFORE all other water treatment equipment and the hot water heater.

Select a location for installation of your system that is within close proximity to the main incoming water lines of the building. The location should have a firm, level surface with sufficient space for the treatment tank and valve. Ensure that there will be enough space surrounding the unit to facilitate maintenance.

You will also need access to a standard, non-switched, grounded 120 volt (60 Hz) electrical outlet. The Fleck 5800SXT control valve comes with a 10 foot long power cord. An extension cord may be used to reach a suitable electrical outlet. If this option is used, ensure that the extension cord is UL/CSA certified and of an appropriate wire gauge for the application.

You will also require a nearby floor drain or standpipe to discharge the drain water from the backwash cycle. A drain standpipe for a washing machine, floor drain, or sump pump are excellent drain options. We recommend that the drain line be connected to a minimum 1½" drain standpipe or floor drain located ideally below the top of the control valve of your system. If possible, the drain should be no farther than 20 feet from the filter system.

Note: Never connect the drain line directly into a drain pipe. Allow an air gap between the drain tubing and waste line to prevent the possibility of back-siphoning. We do not recommend use of a check valve as it may become clogged with contaminants ejected from the system during backwash.

Step 3. – Prepare Treatment Tank

Two types of media are supplied with your Microturb™ system: washed gravel which forms the base layer (underbedding) in your treatment tank, and a specialized sediment/turbidity reduction media called NextSand.

Before you start, gather the main treatment tank, the Fleck 5800SXT control valve, fine screen upper locking stack diffuser, distributor and riser tube assembly (usually shipped inside the tank), funnel, and the bags or boxes of gravel and NextSand. Place the tank in the location where it will sit when the installation is complete. Temporarily, remove the distributor and riser tube assembly from the treatment tank. Hand tighten the Fleck 5800SXT control valve on the tank, and mark where the front of the tank will be. Turn the tank so that the front of the tank is where you want it when it is full – once it is full of media and water, it becomes very heavy and is hard to move!

Remove the control valve and re-insert the distributor and riser tube assembly into the tank. The distributor, which looks like a plastic screen, is pre-connected to the end of the long plastic riser

tube which extends from the bottom of the tank to the top of the tank where the control valve is attached. At the bottom of the tank, there is a recess in the center of the tank to accept the distributor and keep it aligned properly in the center of the tank. The riser tube has been pre-cut to the correct height for you. When the distributor is correctly positioned, the top of the riser tube will be almost perfectly flush with the top of the tank. If the tube is protruding above the tank, the distributor tube is not nested correctly in the recess at the bottom of the tank.

Add enough water to the tank to cover the lower distributor with a minimum of 6 inches of water. This will prevent damage to the lower distributor as gravel is loaded. Place the funnel into the tank so that the riser tube is in the middle. Place tape over the open end of the riser tube. This will prevent gravel or media from accidentally going down the tube during the following steps.

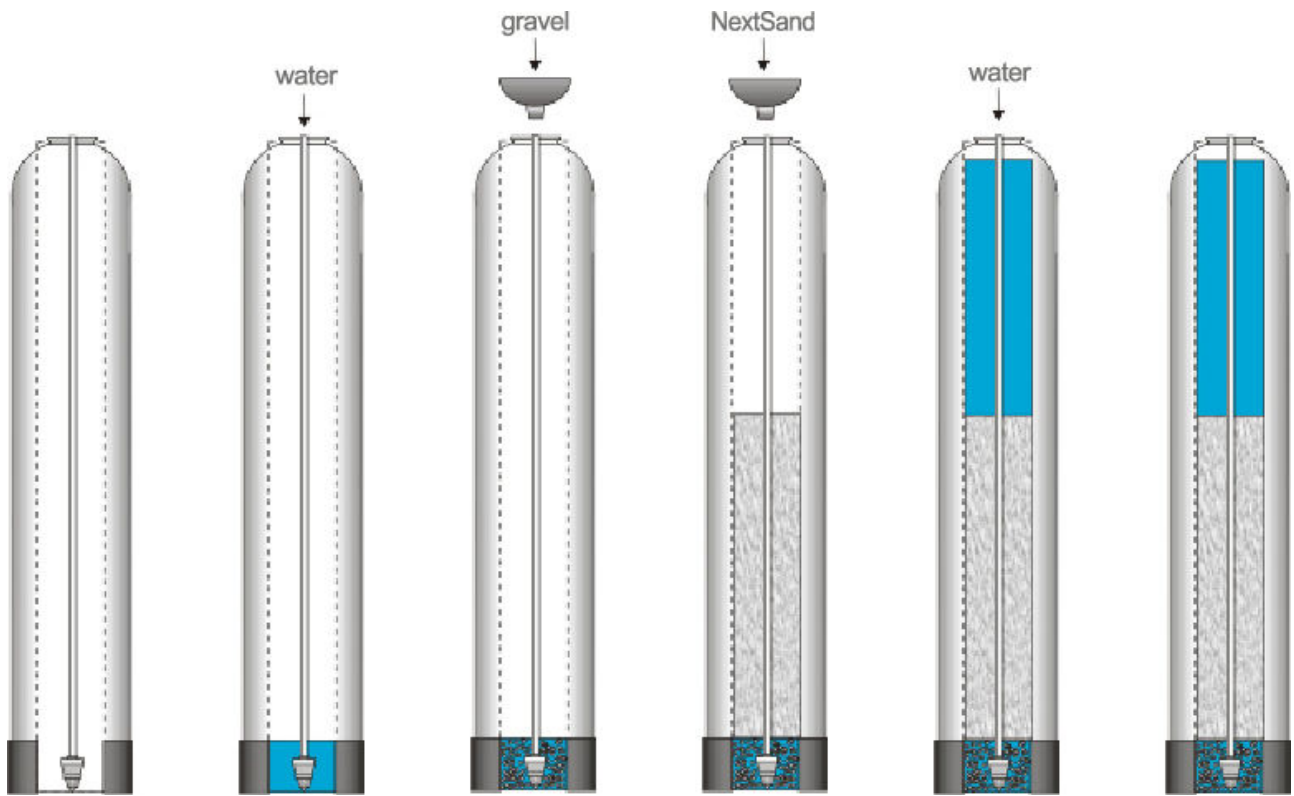

For the following steps, we recommend that you wear a dust mask. Take the bag/box of gravel and using a small scoop, add the gravel to the tank through the funnel. The gravel should completely cover the distributor plus about 1 to 2 inches above. Be sure to provide some pressure on the riser tube while adding the gravel so as to ensure that the distributor does not shift out of its recess. Ensure that you create an even layer of gravel across the bottom of the tank. A rigid piece of tubing (conduit, copper pipe, etc.), approximately 1" longer than the tank height works well as a leveling tool. As the tank fills, ensure that the riser tube remains centered in the opening at the top of the tank.

Once this is complete, add the NextSand media in the same manner. Depending on the capacity of the system, there will only be enough media to fill the tank to about 1/2 to 2/3 full. Use all of the

media provided. The treatment tank should never be filled to the top of the tank as the remaining space, known as the “freeboard” is necessary for the media to have room to move during the backwash cycle.

Once you have finished adding the media to the tank, remove the tape from the distributor tube. Be careful not to pull upwards on the riser tube while doing this as it is important that the distributor remain in its recess at the bottom of the tank.

Fill the treatment tank with water up to within a couple of inches of the top of the tank. This will allow the media to pre-soak, thereby preventing media loss during the initial backwash.

If you purchased an optional tank jacket kit, install it now.



DO NOT INITIATE A REGENERATION OF THIS SYSTEM FOR A MINIMUM OF 2 HOURS AFTER ADDING THE WATER TO ALLOW ADEQUATE PRE-SOAKING – BACKWASHING BEFORE THE MEDIA IS SATURATED WILL CAUSE A LOSS OF MEDIA AND POTENTIAL DAMAGE TO THE CONTROL VALVE.

Attach the upper locking stack diffuser onto the underside of the control valve. Be sure to twist clockwise to lock into place.

Lubricate the tank O-ring seal. Also place a small amount of lubricant on the outside of the top 3 inches of the rise tube. Note: Only use food-grade silicone lubricant. Do NOT use petroleum jelly.

The Fleck 5800SXT control valve (head) can now be secured to the top of the tank. Before attaching the valve, check to make sure that there is no debris such as gravel or media in the tank threads. Screw the control valve onto the tank – make sure that the riser tube inserts into the center hole in the upper stack diffuser and the control valve as you screw down the valve. The control valve should be hand-tightened (clockwise). Do not use the control valve's timer assembly for leverage and do not use tools. A firm grasp with both hands at the base of the valve will work. Do NOT use pipe cement (“pipe dope”) or Teflon tape on the valve threads.

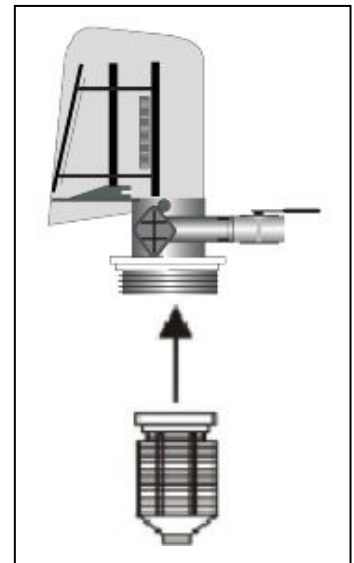

Step 4. – Turn off the Water & Electric Water Heaters

Turn off the household main water shutoff valve. Open all plumbing fixtures inside the home as well as the outside faucets to drain as much water out of the plumbing system as possible.

If you have a conventional electric water heater or an on-demand (tankless) electric water heater, we highly recommend that you turn off the electricity to the heater while installing any water treatment equipment. Following completion of the entire installation, restore the water flow by

turning on the household main water valve and allow all air to be purged from the plumbing system before turning the power back on to your water heater. **Failure to follow this procedure could result in serious, permanent damage to the heating elements in your water heater.**

Step 5. – Prepare and Install Inlet and Outlet Plumbing Connections

Note: Teflon[®] tape is the only sealant to be used on the bypass and drain fittings.

A bypass assembly is included with your system. Depending on the size of your system, the bypass will generally have 3/4" or 1" NPT threaded fittings to connect to your main incoming and outgoing water lines. You will need to purchase the appropriate NPT threaded fittings to connect to the material and size of your main water line (inlet and outlet). Locate the inlet and outlet ports on the back of the Fleck 5800SXT control valve. Note that the inlet and outlet are marked with arrows indicating the correct direction of water flow (visible from side view). When you are looking at the back of the control valve, the inlet is on the left and the outlet is on the right. Check the corresponding markings on the bypass to ensure the correct direction of water flow and insert the bypass (do not secure the clips yet). The in and out arrows on the bypass should be pointing the same direction as the in and out arrows on the side of the control valve.

BE VERY CAREFUL TO MAKE SURE YOU PLUMB THE SYSTEM IN THE RIGHT DIRECTION, OTHERWISE THE SYSTEM WILL NOT FILTER EFFECTIVELY AND YOU COULD LOOSE THE MEDIA OUT OF THE TANK INTO YOUR HOUSE LINES.

Plumb your main incoming and outgoing water lines using suitable pipe, fittings, elbows, etc. as necessary to create a tidy, secure installation up to the back of the bypass valve (including the correct connection adapters to mate with the threaded fittings on the bypass). Be sure to follow all local plumbing codes.

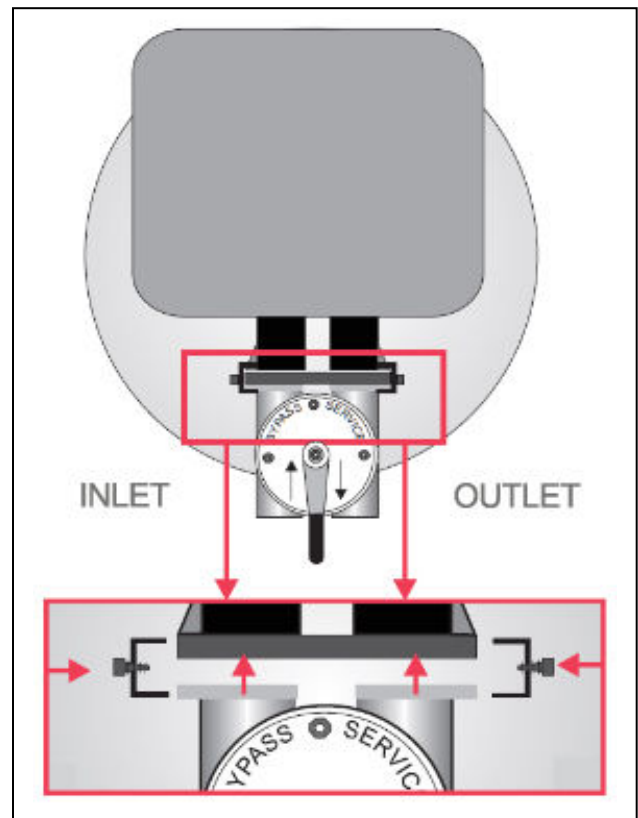

VERY IMPORTANT:



If you wish to use copper piping and will be soldering the joints, **DO NOT** apply heat near your control valve or bypass or serious internal damage to these parts could occur. Always solder joints with these components detached. If you are using copper adapters, it is recommended that you solder a 5" piece of copper pipe into each of the connection adapters away from the valve, then let them cool off before threading them onto the bypass valve. After they cool off, apply Teflon tape to the threads and securely tighten them to the bypass valve.

Once you have prepared the plumbing up to the point of the bypass following the above instructions, you can connect your plumbing lines to the bypass valve. We highly recommend that you remove the bypass before making these connections as you may inadvertently apply too much pressure on the valve while securing the adapters, causing damage to the valve housing.

Once all plumbing to the bypass has been completed, you can connect the bypass to the control valve. Push the bypass onto the back of the valve and secure it using the two stainless steel clips with screws located on the back of the control valve. Do not overtighten - it is normal for some “play” to exist when the bypass valve is properly seated. This allows for minor misalignment of the piping connections and relieves stress on the valve.

Place the bypass valve in the “bypass” position.

Step 6. – Drain Line Installation

During the backwash cycle, your MicroTurb™ will send captured contaminants out the drain port. This port needs to be connected to a suitable household drain ideally within 20 feet of your treatment tank. A nearby floor drain, sump pump, or a standpipe for a washing machine are good drain options. We recommend that the drain line be connected to a minimum 1 1/2" drain standpipe or floor drain located ideally below the top of the control valve of your MicroTurb™ system. You will need to purchase suitable pipe or tubing for the drain line. The minimum diameter of the drain line should match the threaded fittings on the drain line flow control supplied with your system. While polyethylene tubing or copper pipe is suitable, we recommend rigid PVC or CPVC pipe for the drain line. If you are using flexible tubing, be sure that there are no “kinks” or “crimps” in the tubing after installation that could cause a flow restriction. If used, overhead drain lines are not to exceed a height of 5 feet above the control valve and should be no more than 50 feet in length. Should an overhead drain line be utilized, it is recommended that the drain line be increased in size (diameter), and that it not be fastened flush to the bottom of a floor joist, to minimize noise transfer during backwash.

Locate the drain port on the side of your valve controller. A drain line flow control (DLFC) with NPT threaded fitting is included with your system and is generally shipped attached to the valve. To remove the drain line flow control from the drain port, remove the retaining clip and then grasp the drain line flow control and pull outward. For smaller systems, the DLFC will be a plastic fitting with a button restrictor inside. For larger capacity systems, it will be a 2 part brass and/or stainless steel assembly.

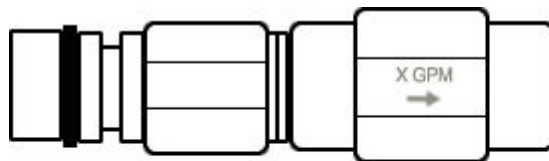

Drain Line Flow Restrictor
For High-Flow Applications
(Brass and/or Stainless Steel)

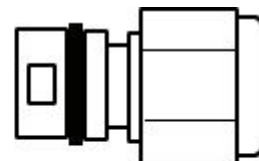

Drain Line Flow Restrictor
For Lower-Flow Applications
(Plastic)

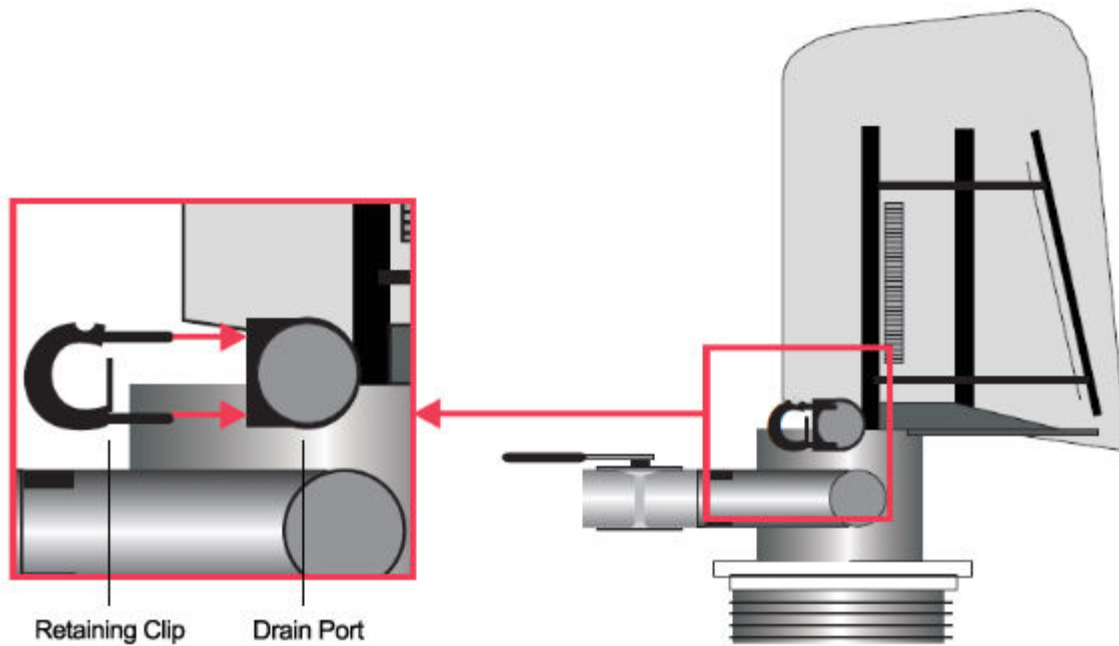

Using an appropriate fitting, connect the NPT threaded outlet of the drain line flow control to your drain line tubing/pipe. You may wish to dry-fit the fitting first to make sure you line up the drain line properly with the drain port on the control valve if you are using rigid pipe.

To install the drain line flow control, first, remove the drain line flow control retaining clip. Then, insert the drain line flow control into the drain port with a firm push and replace the clip to secure it.

Ensure that the drain line is secured along its route to the drain. The drain line will be under pressure when the backwash cycle is working, therefore make sure the drain line is well secured so it can not move around when pressurized. If not adequately secured, the drain line could vibrate during backwash causing excessive noise. If this is experienced, use additional fasteners to better secure the drain line. The drain line should not be exposed to freezing temperatures.

Note: Never connect the drain line directly into a drain. Allow an air-gap of a minimum of 1 inch (check local codes) between the drain line and waste line to prevent possibility of back-siphon. Always follow local codes.

Step 7 – Control Valve Set-up

During cold weather, the installer should warm the control valve to room temperature before operating. Note: All electrical connections must be done according to local codes.

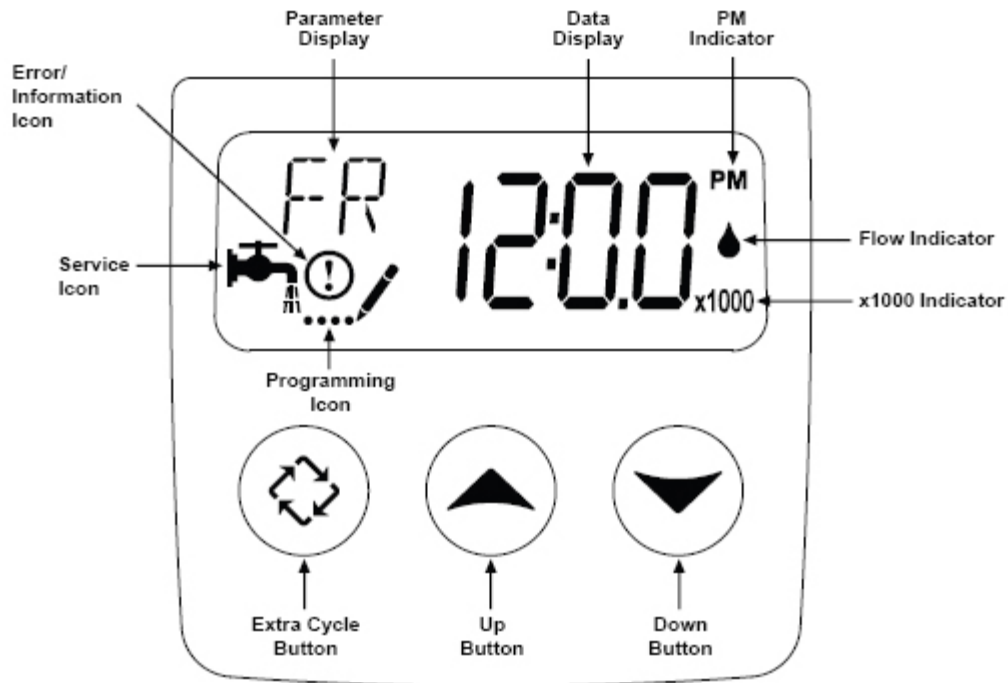

Plug the control valve into a standard, grounded 120 volt (60 Hz) electrical outlet. Be certain that the outlet is uninterrupted and not controlled by a switch. The Fleck 5800SXT control valve comes with a 10 foot long electrical cord. An extension cord may be used to reach a suitable electrical outlet. Ensure that the extension cord is UL/CSA certified and of an appropriate wire gauge for the application. Plug the other end of the power cord into the electrical port on the control valve.

Note: The electrical port on the control valve is located on the right side of the valve (when you are facing the control panel), just behind the tab used to remove the valve cover. It is a bit tricky to find... see the diagram below:

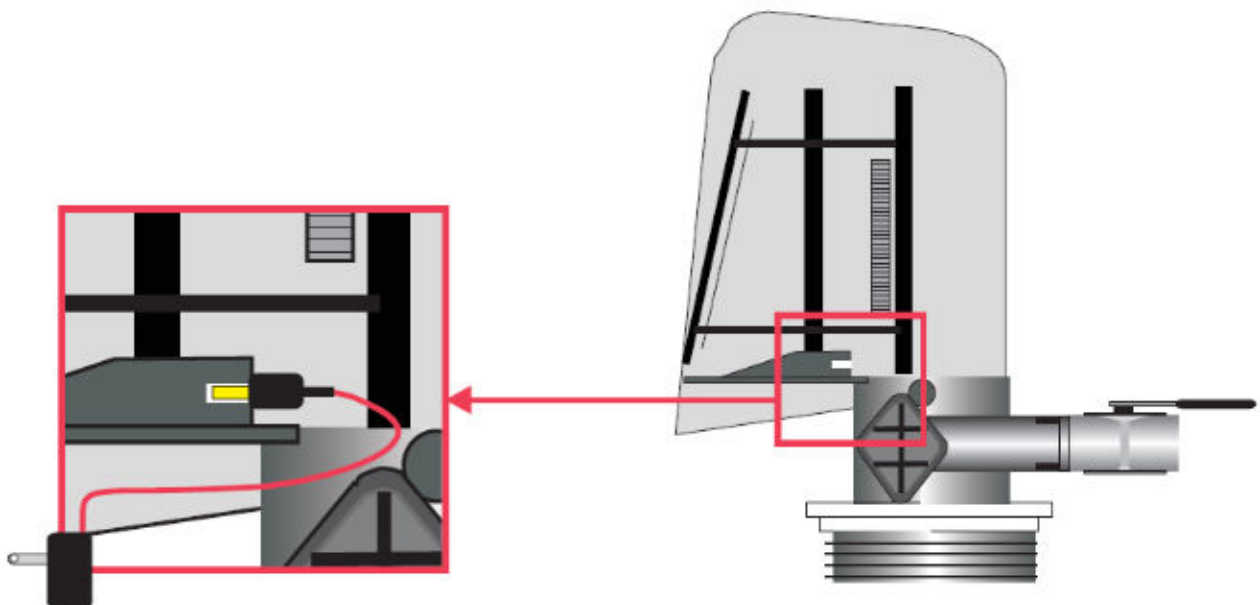

Once plugged in, the digital display on the control valve will illuminate. **NOTE:** The control valve may need to reset to the home position when it is powered up. If it does, the motor will run for a few seconds.

The digital display should be alternating between the current time setting (which is probably incorrect), and the number “5” which indicates the number of days remaining until the next backwash cycle. You will also see the “in service” icon which appears as a small faucet in the bottom left corner of the display window.

We will first set the time of day to the correct time. Press either the UP or DOWN button and hold for a few seconds. The parameter display will read “TD” (Time of Day) and the “programming” mode icon will appear (4 dots and a pencil). Use the UP and/or DOWN buttons to change the time displayed to the correct time of day. Once the display shows the correct time, press the EXTRA CYCLE button to save your changes.



Your MicroTurb™ has been pre-programmed to backwash every 5 days and to perform the backwash process at 12:30am in the morning when it is very unlikely that water will be required in the building. You may edit the frequency and duration of the backwash based on your water conditions. You may also alter the time of day that the backwash process occurs if 12:30am is not ideal for you. If you have a water softener or other automatic backwashing water treatment systems, make sure that they are not set to regenerate at the same time. We recommend that they backwash/regenerate at least 90 minutes apart. Follow the instructions under “User Programming Mode” to change the frequency or backwash time if desired. If you want to change the duration of the backwash or final rinse cycles, these settings must be edited in the “Master Programming Mode” – see below for details.

Step 8 – Initial Start-up and Leak Testing

Ensure that the bypass is in the bypass position. Turn on the main water supply. Open a cold water tap nearby and let the water run for a few minutes or until the system is free of foreign material (usually solder) and air that may have resulted from the installation. Once clean, close the water tap. Inspect your plumbing connections for leaks and repair any leaks found before proceeding.



DO NOT INITIATE A BACKWASH OF THIS SYSTEM FOR A MINIMUM OF 2 HOURS AFTER ADDING WATER TO THE TREATMENT TANK TO ALLOW ADEQUATE PRE-SOAKING . BACKWASHING BEFORE THE MEDIA IS SATURATED COULD CAUSE A LOSS OF MEDIA AND POTENTIAL DAMAGE TO THE CONTROL VALVE.

Before putting the system into service, it is important that the media soak for a minimum of 2 hours before you proceed with the remainder of the installation.

Once the media has been adequately pre-soaked for 2 hours:

WITH THE BYPASS STILL IN THE BYPASS POSITION, press the EXTRA CYCLE button and hold it down for about 5 seconds until you hear the valve change positions, the parameter display changes to read “BW” (Backwash), and the time starts counting down. Once the motor has stopped moving (no more noise), press the EXTRA CYCLE button again to advance to the next stage of the backwash cycle – “RR” (Rapid Rinse).

Without delay, immediately begin to slowly open the bypass to the service position, allowing water to flow into the system. Water and air will begin to flow to the drain line and will continue for 2 minutes. At the end of this time, the valve will re-position and the filter will return to normal service mode. Inspect your drain line plumbing connections and repair any leaks immediately before proceeding. If the plumbing pipe rattled or vibrated during this process causing excessive noise, use additional fasteners to better secure the drain line.

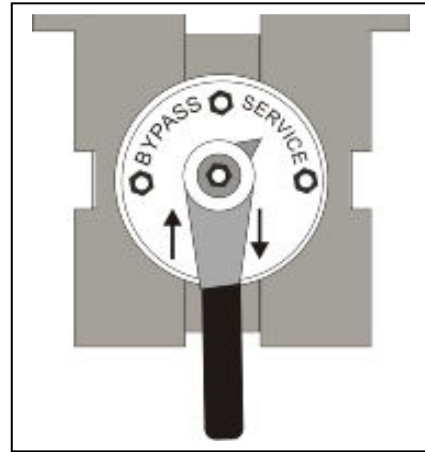

Slowly open a nearby cold water tap (after the MicroTurb™ system) and let the water run for 5 minutes until the system is purged of all air that may have resulted from the installation. Repeat for other faucets in the building starting at the highest elevation and working down to the lowest point until all air is purged. The initial flow of water may be slightly discolored. This is normal and will go away quickly.

It is now safe to turn the electricity back on to your water heater.

Congratulations! Your system is now ready to provide treated water to your home!

BACKWASH

The backwash process is automatically engaged and controlled by your control valve. Your system was pre-programmed at the factory. In most cases, your system will be programmed to backwash every 5 days at 12:30am.

There are 2 steps to the backwash process:

Step 1: Backwash: factory pre-set for 10 minutes (parameter display code BW)

Step 2: Rapid Rinse: factory pre-set for 2 minutes (parameter display code RR)

Unless directed by a water treatment professional familiar with this system, we do not generally recommend that you alter the duration of any cycles, however, you can adjust the duration of both cycles based on your water conditions thru the Master Programming Mode (see below). If you experience reduced service flow rate and pressure loss due to clogging, it is recommended that you increase the frequency and/or duration of your backwash. If on the mornings after a backwash, your water is often discolored or has evidence of sediment, increase the duration of the rapid rinse cycle in 1 minute increments until the problem is resolved.

During each step of backwash, the digital display on the control valve will indicate the cycle currently underway and the amount of time remaining in that cycle.

There may be instances where more frequent backwash is required. For instance, if your water consumption increases considerably, or if your feed water conditions temporarily worsen, you may want to perform a manual backwash. You can choose to initiate a manual backwash immediately or the next time the backwash time of day is reached:

To initiate a manual backwash the next time the backwash time of day is reached:

Press the EXTRA CYCLE button once. The “service” icon will begin to flash indicating that a backwash is scheduled next time the backwash time of day is reached.

To cancel a queued backwash, press the EXTRA CYCLE button.

To initiate an immediate manual backwash:

Press the EXTRA CYCLE button and hold it down for 5 seconds until the backwash process begins.

Skip through backwash steps:

There may be times that it may be desirable to skip through backwash steps without allowing them to fully complete. This would be most typical during servicing. When a cycle engages, always wait until the motor has stopped before skipping to the next cycle. You can hear the valve motor while it is repositioning the valve at the beginning of each cycle. During the backwash process, you can advance to the next step by pressing the EXTRA CYCLE button.

The control valve will continue to keep time and the passage of days for a minimum of 48 hours in the event of power failure.

CHANGING TIME OF DAY

During regular service mode, the digital display will alternate between the current time of day and the number of days until the next scheduled regeneration. For proper operation, it is important that the valve display the correct time of day. To change the time of day, press either the UP or DOWN button and hold for a few seconds. The “programming” icon will appear. Use the UP

and/or DOWN buttons to change the time displayed to the correct time of day. Once the display shows the correct time, press the EXTRA CYCLE button to save your changes.



USER PROGRAMMING MODE

The User Programming Mode allows you to set the frequency of backwash and the time of day that backwash will take place.

To enter the User Programming Mode, press the UP and DOWN arrows at the same time and hold for 5 seconds until the “programming” mode icon appears. If the current time display is 12:01PM, you cannot enter the User Programming Mode – simply wait a minute before attempting.

The display will first show the **DAYS OVERRIDE** (parameter display code DO). This is the setting that determines the frequency of backwash (measured in days). It is generally recommend that the system backwash at least every 5 days. Failure to do so, could result in loss of water pressure due to media clogging.

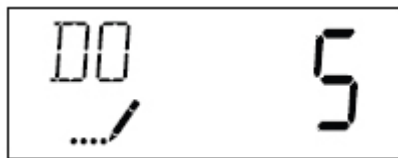

To change the setting, use the UP and DOWN buttons. Press the EXTRA CYCLE button when done. If you do not want to change the current setting, simply press the EXTRA CYCLE button to skip to the next step.

The display will now show the **REGENERATION (BACKWASH) TIME** (parameter display code RT). This is the setting that determines the time of day that the automatic backwash will start. It is strongly recommended that backwash be set to occur at night when water will not be in use. If you have other water treatment equipment that backwashes (such as a water softener or iron filter), make sure that your MicroTurb™ is not set to backwash at the same time.

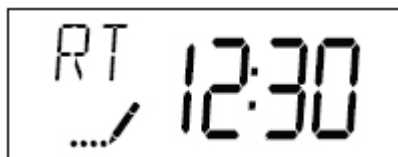

To change the setting, use the UP and DOWN buttons. Press the EXTRA CYCLE button when done. If you do not want to change the current setting, simply press the EXTRA CYCLE button to return to service mode.

The system should now return to normal service mode. The unit will also return to normal operation after 5 seconds if no buttons are pressed.

MASTER PROGRAMMING MODE

The Master Programming Mode is designed for professional use only. Unless directed by a water treatment professional familiar with the system, it is not recommended that any of the Master Programming Mode settings be modified except as discussed in this manual.

To enter the Master Programming Mode, first set the time of day to 12:01PM. With the time display showing 12:01PM, enter the Master Programming Mode, by pressing the UP and DOWN arrows at the same time and holding for 5 seconds until the “programming” mode icon appears.

In this mode, you can adjust a parameter setting by using the UP and DOWN buttons. To save your changes and/or to skip to the next parameter, press the EXTRA CYCLE button. Press the EXTRA CYCLE button at the last parameter to save all settings and return to normal operation. The control will automatically disregard any programming changes and return to normal operation if it is left in Master Programming Mode for 5 minutes without any keypad input. The following settings are the factory default settings for all MicroTurb™ systems:

Parameter	Parameter Code	Option Code	Option Description
Display Format	DF	GAL	Gallons
Valve Type	VT	5800	Fleck 5800
Regenerant Flow	RF	Fltr	Filter
Control Type	CT	tc	Time Clock
Day Override	DO	5	Every 5 days
Regeneration Time	RT	12:30	12:30am
Backwash	BW	10	10 minutes
Rapid Rinse	RR	2	2 minutes

RESETS

WARNING: USE OF THE RESET FUNCTIONS IS NOT RECOMMENDED EXCEPT UNDER THE GUIDANCE OF A WATER TREATMENT PROFESSIONAL FAMILIAR WITH THIS EQUIPMENT.

Soft Reset: Press and hold the EXTRA CYCLE and DOWN buttons for 25 seconds while in normal Service mode. This resets all parameters to the system default values except days since backwash in the time clock system.

Master Reset: Hold the Extra Cycle button while powering up the unit. This resets all of the parameters in the unit. Check and verify the choices selected in Master Programming Mode.

CONTROL OPERATION DURING A POWER FAILURE

The 5800SXT valve/controller includes integral power backup. In the event of power failure, the control shifts into a power-saving mode. The control stops monitoring water usage, and the display and motor shut down, but it continues to keep track of the time and day for a minimum of 48 hours.

The system configuration settings are stored in a non-volatile memory and are stored indefinitely with or without line power. The Time of Day flashes when there has been a power failure. Press any button to stop the Time of Day from flashing.

If power fails while the unit is in backwash, the control will save the current valve position before it shuts down. When power is restored, the control will resume the backwash cycle from the point where power failed. Note that if power fails during a backwash cycle, the valve will remain in its current position until power is restored. The drain line plumbing configuration should include all required safety components to prevent overflows resulting from a power failure during backwash.

The control will not start a new backwash cycle without power. If the valve misses a scheduled backwash due to a power failure, it will queue a backwash. Once power is restored, the control will initiate a backwash cycle the next time that the Time of Day equals the programmed backwash time. Typically, this means that the valve will backwash one day after it was originally scheduled.

MAINTENANCE & TROUBLESHOOTING

WARNING: The controller MUST be depressurized before removing any quick connection clips for servicing. The connector should be pushed toward the control while removing clips.

Service Recommendations

Your Fleck 5800 valve is built for long term operation with limited maintenance. In harsh conditions, particular where water is acidic, highly contaminated, or where excessive levels of hydrogen sulfide are present, the seals and spacers and piston assembly may require periodic servicing or replacement. A service professional should be contacted for this maintenance.

NextSand media should generally be replaced every 5 years. Inadequate backwash duration or flow rates could cause media clogging which could require the replacement of the media to restore flow and pressure performance.

Troubleshooting

PROBLEM	CAUSE	CORRECTION
1. Valve fails to backwash	A. Electrical service to unit has been interrupted. B. Timer is defective.	A. Assure permanent electrical service (check fuse, plug, pull chain or switch). B. Replace timer.
2. Loss of water pressure.	A. Contaminant build-up in feed line B. Contaminant build-up in unit C. Inlet of control plugged due to foreign material broken loose from pipe by recent work done on plumbing system.	A. Clean line to water filter. B. Perform manual backwash. Increase frequency of regeneration and/or backwash time. C. Remove pistons and clean control.
3. Loss of media through drain line.	A. Drain line flow control too large.	A. Check to ensure drain line flow control is sized properly for your treatment tank.

ERROR CODES

Code	Error	Cause	Reset & recovery
0	Cam Sense Error	The valve drive took longer than 6 minutes to advance to the next regeneration position.	Unplug the unit and examine the control valve. Verify that all cam switches are connected to the circuit board and functioning properly. Verify that the motor and drive train components are in good condition and assembled properly. Check the valve and verify that the piston travels freely. Replace/reassemble the various components as necessary. Plug the unit back in and observe its behavior. The unit should cycle to the next valve position and stop. If the error re-occurs, unplug the unit and contact technical support.
1	Cycle Step Error	The control experienced an unexpected cycle input.	Unplug the unit and examine the control valve. Verify that all cam switches are connected to the circuit board and functioning properly. Enter Master Programming mode and verify that the valve type and system type are set correctly with regard to the unit itself. Step the unit through a manual regeneration and verify that it functions correctly. If the error re-occurs unplug the unit and contact technical support.
2	Regen Failure	The system has not regenerated for more than 99 days.	Perform a Manual Regeneration to reset the error code. Enter Master Programming mode and verify that the unit is configured properly. As appropriate for the valve configuration, check that the correct system capacity has been selected, and that the day override is set properly. Correct the settings as necessary.
3	Memory Error	Control board memory failure.	Perform a Master Reset and reconfigure the system via Master Programming mode. After reconfiguring the system, set the valve through a manual regeneration. If the error re-occurs, unplug the unit and contact technical support.

WARRANTY INFORMATION

Your MicroTurb™ system components, other than the NextSand media, are warranted by HomePlus Products Inc. to be free of defects in material and workmanship for the following periods from the date of purchase provided that your system was purchased from an Authorized dealer; operated in accordance with operating conditions stated herein; and provided that it was installed in accordance with these instructions:

Tank: 10 years

Control Valve: 3 years

All Other Components: 1 year

There is no warranty on the NextSand or gravel media.

This warranty applies only in Canada and the United States of America.

In the event that a part is deemed defective, the user must immediately inform HomePlus Products Inc. who will furnish a replacement part at no cost to the user.

This warranty does not cover shipping costs or any labour costs related to troubleshooting, installation, or maintenance.

The warranty does not apply to the following situations: misuse; normal wear and tear; neglect; unauthorized repair or damage caused through installation, adaptation, or modification; use in an improper manner or manner inconsistent with these operating and maintenance instructions; wear or deterioration due to environmental conditions; damage occurring during transit; mishandling; improper storage; incorrect supply of water; tampering or alteration; act of god; or any cause beyond the control of HomePlus Products Inc.

The original warranty period does not change in the event of part replacement by HomePlus Products Inc.

The warranty is issued exclusively to the original consumer purchaser of record and is not transferable.

The provisions of the foregoing warranty are in lieu of any other warranty, whether express or implied, written or oral (including any warranty of merchantability or fitness for a particular purpose). HomePlus Product Inc.'s liability arising out of the manufacture, sale, or supplying of the products or their use or disposition, whether based upon warranty, contract, tort, or otherwise, shall not exceed the actual purchase price paid by the authorized distributor or consumer for the product. In no event shall HomePlus Products Inc. be liable to the distributor or any other person or entity for special, incidental, consequential or punitive damages (including, but not limited to, property loss, loss of incomes, or loss of use damages) arising out of the

manufacture, sale, or supplying of the products, even if HomePlus Products Inc. has been advised of the possibility of such damages or losses.

HomePlus will not be liable under this warranty for any fault or damage arising from defective workmanship if the product has been modified by any person other than HomePlus Products Inc.

Proof of purchase is required for warranty service.

**To report a warranty problem with your system, please call HomePlus Products Inc.
Toll free: 1-866-376-2690**

MANUFACTURED BY:



HomePlus Products Inc.

5-1490 Pearson Place
Kamloops, BC V1S 1J9
Canada

Phone: 250-374-2690

Fax: 250-374-2692

www.homeplusproducts.com