

# OWNER'S MANUAL & INSTALLATION GUIDE

**TITAN-Ox**



## TITAN-Ox™ Arsenic and Heavy Metal Reduction Filters

highly effective and economical treatment for the removal of arsenic, uranium, lead, and other heavy metals!

APPLICABLE MODELS: TOx-5800SXT Series

**PLEASE READ THIS MANUAL CAREFULLY BEFORE ATTEMPTING INSTALLATION. FAILURE TO FOLLOW THESE INSTRUCTIONS MAY AFFECT THE PERFORMANCE OF YOUR SYSTEM, VOID YOUR WARRANTY, AND RESULT IN PROPERTY DAMAGE.**

## Congratulations on the purchase of your TITAN-Ox™ Series arsenic and heavy metal filtration system.

You have purchased one of the finest arsenic treatment systems on the market today. All TITAN-Ox™ Series water treatment systems utilize the world's most advanced titanium dioxide media to remove arsenic (both arsenic III and arsenic V), uranium, lead, cadmium, copper, chromium +6, selenium, zinc and other heavy metals. Our titanium dioxide outperforms iron and alumina-based removal systems – it has a high adsorbent capacity and reacts quickly. It is long lasting and more environmentally-friendly. When the media has reached exhaustion, it is non-hazardous and may be landfilled without concern about leaching trapped contaminants back into the ecosystem. No chemical regeneration of the media is required and backwash requirements are minimal so water is not wasted.

The brain of your TITAN-Ox™ system is the Fleck 5800SXT control valve. It is manufactured by one of the world's premier water treatment companies. The Fleck 5800 control valve is well respected for its reliability, serviceability, simple operation, and value. The integrated Fleck SXT digital valve controller offers unsurpassed simplicity of operation, yet complete control over all important valve operations. The Pentair Fleck 5800SXT Downflow/Upflow Service Manual is also included with your system. It includes additional information regarding the operation of your valve, replacement parts lists, and more.

Your TITAN-Ox™ water treatment system is designed to offer low maintenance operation. The control valve will perform regular backwash functions automatically. For your convenience, your system has been pre-programmed for you at our factory. Should you need to change any of the settings, simply follow the instructions provided in this manual.

---

## IMPORTANT SAFETY SYMBOLS



Hazards or unsafe practices that may result in personal injury and/or severe property damage.



Hazards or unsafe practices that may cause operational problems with your water treatment system.

## Table of Contents:

|   |    |
|---|----|
| GENERAL WARNINGS .....  | 4  |
| OPERATING CONDITIONS .....  | 5  |
| INSTALLATION .....  | 7  |
| Step 1 – Pre-Installation Inspection .....                              | 7  |
| Step 2 – Selecting an Installation Location .....                       | 8  |
| Step 3 – Prepare Treatment Tank .....                                   | 9  |
| Step 4 – Turn off the Water & Electric Water Heaters .....              | 12 |
| Step 5 – Prepare and Install Inlet and Outlet Plumbing Connection ..... | 12 |
| Step 6 – Drain Line Installation .....                                  | 15 |
| Step 7 – Control Valve Set-up .....                                     | 16 |
| Step 8 – Initial Start-up and Leak Testing .....                        | 18 |
| PERFORMANCE MONITORING .....  | 20 |
| BACKWASH .....  | 21 |
| CHANGING TIME OF DAY .....  | 22 |
| USER PROGRAMMING MODE .....   | 23 |
| MASTER PROGRAMMING MODE .....   | 24 |
| RESETS .....  | 25 |
| OPERATION DURING A POWER FAILURE .....                                  | 25 |
| MAINTENANCE & TROUBLESHOOTING .....                                     | 26 |
| WARRANTY INFORMATION .....  | 28 |

## GENERAL WARNINGS



Do not allow children or pets to play on or around the water filter.

Do not install or store this filter system where it will be exposed to freezing temperatures.

Do not tamper with controls.

Do not repair, replace, or attempt to service any part of the system unless specifically instructed to in this manual and you have the understanding, tools, and skills necessary to carry out the procedure.

Packing materials can be dangerous to children. Keep all packing material (plastic bags, polystyrene, boxes, etc.) well out of children's reach.

Individual components of this water treatment system, and the installed system, are heavy. Precautions should be taken to prevent personal injury or strain. Do not move heavy components without assistance if you are not physically capable of safely carrying out the procedure.

If the water treatment system is to be left unattended for an extended period of time (vacation, etc.), we strongly recommend that you turn off the water supply to the system, or the whole house, while you are away.

If your water pipes are metal (galvanized or copper), they may be used to ground electrical systems, appliances, or your phone line. If this is the case, be sure to install regulation ground clamps to the metal pipe on each side of the control valve and connect a jumper wire between the 2 clamps (#4 gauge solid copper wire recommended). Consult a certified electrician or plumber if you are unsure.

**CRITICAL NOTE: THE CONTAMINANTS TARGETED BY THIS WATER TREATMENT EQUIPMENT HAVE THE POTENTIAL TO CAUSE SERIOUS ADVERSE HEALTH EFFECTS. WE STRONGLY RECOMMEND AN ONGOING REGIMEN OF FOLLOW-UP WATER TESTING TO CONFIRM THE PERFORMANCE OF THE SYSTEM AND THE MAINTENANCE OF CONTAMINANT LEVELS BELOW THE U.S. EPA AND HEALTH CANADA GUIDELINES.**

## OPERATING CONDITIONS

The following chart provides guidance on the conditions required for successful operation of your TITAN-Ox™ system.

Dissolved iron and manganese have a significant negative impact on the life of the Titanium dioxide treatment media used in the TITAN-Ox™ system. Pre-treatment to remove iron is strongly recommended where iron levels exceed 0.3 ppm (mg/l), and/or if manganese levels exceed 0.05 ppm (mg/l), and may be desirable to extend media life even where the iron and manganese in your raw water do not exceed these levels. Media life and performance is significantly reduced when the pH exceeds 8.3. If pH exceeds this level, pH correction should be undertaken prior to the TITAN-Ox™ system. Elevated levels of silica and/or sulfate may reduce media life depending on other water chemistry conditions (particularly if the water is soft). Pre-filtration to remove sediment and particulates will reduce required backwash frequency.



**FOR IDEAL CONTAMINANT REDUCTION RATES, THE OPTIMAL FLOW RATE SHOULD NOT BE EXCEEDED. THE LOWER THE FLOW RATE, THE HIGHER THE CONTAMINANT REDUCTION RATES WILL BE. SATISFACTORY PERFORMANCE CAN GENERALLY BE ACHIEVED UP TO THE RECOMMENDED PEAK FLOW RATE AS LONG AS THIS LEVEL OF FLOW RATE IS NOT SUSTAINED CONTINUOUSLY.**

**USE OF THIS EQUIPMENT OUTSIDE OF THESE OPERATING CONDITIONS MAY ADVERSELY AFFECT THE PERFORMANCE OF YOUR SYSTEM, RESULT IN SYSTEM DAMAGE INCLUDING WATER LEAKS AND CORRESPONDING PROPERTY DAMAGE, AND MAY VOID YOUR WARRANTY.**

|                            |                        |
|----------------------------|------------------------|
| Minimum Water Pressure     | 20 PSI                 |
| Maximum Water Pressure     | 90 PSI*                |
| Recommended Water Pressure | 40-70 PSI              |
| Water Temperature          | 36F to 100F (2 to 38C) |
| Minimum Air Temperature    | 32°F (0°C)**           |
| pH Range                   | 5.0*** to 8.3          |
| Maximum Iron               | 0.3 ppm (mg/l)         |
| Maximum Manganese          | 0.05 ppm (mg/l)        |
| Maximum Arsenic            | See note below         |

\* While the TITAN-Ox™ system is built to withstand pressures exceeding 90 PSI, if your water pressure is greater than 70 PSI, we recommend that you have a certified plumber install a pressure reducing valve ahead of the TITAN-Ox™ system.

\*\* The system cannot be subjected to freezing conditions or severe damage to the system and your property could occur.

\*\*\* pH correction is strongly recommended where pH levels are less than 6.5 to prevent damage to your control valve and plumbing system, and to prevent leaching of metals from copper and brass plumbing components and solder in your home. Contact your dealer for recommendations.



**IF YOUR TOTAL ARSENIC LEVEL IS GREATER THAN 60 PARTS PER BILLION (0.060 MG/L), PLEASE CONTACT ONE OF OUR CERTIFIED WATER TECHNICIANS FOR SIZING ASSISTANCE (PHONE TOLL FREE 1-866-376-2690). A LEAD/LAG CONFIGURATION OR LARGER MEDIA VOLUME MAY BE REQUIRED FOR DESIRED TREATMENT.**

**TITAN-Ox™ Series Flow Rates & Backwash Requirements:**

| Model             | Optimal Service Flow Rate* (GPM) | Maximum Service Flow Rate* (GPM) | Backwash Flow Rate at 40F Water Temp (GPM) | Backwash Flow Rate at 70F Water Temp (GPM) |
|-------------------|----------------------------------|----------------------------------|--|--|
| TOx-5800SXT-10-54 | 2.7                              | 5.5                              | 4.5  | 6  |
| TOx-5800SXT-12-52 | 3.9                              | 7.9                              | 7  | 8  |
| TOx-5800SXT-13-54 | 4.6                              | 9.2                              | 8  | 10   |
| TOx-5800SXT-14-65 | 5.3                              | 10.7                             | 9  | 12   |



**CONFIRM THAT YOUR WATER CONDITIONS, SERVICE FLOW RATE NEEDS, AND AVAILABLE BACKWASH FLOW RATES MEET THE ABOVE SPECIFICATIONS FOR THE MODEL YOU ARE INSTALLING BEFORE COMMENCING THE INSTALLATION PROCESS. IF IN DOUBT, CALL YOUR DEALER FOR ADVICE. INSTALLED UNITS CANNOT BE RETURNED.**

# INSTALLATION



**WE RECOMMEND THAT YOU READ THIS ENTIRE MANUAL BEFORE STARTING THE ACTUAL INSTALLATION. WHILE WE STRONGLY RECOMMEND THAT A LICENSED PLUMBER PERFORM ALL INSTALLATION WORK, A MECHANICALLY-INCLINED HOMEOWNER WITH SUITABLE PLUMBING KNOWLEDGE CAN INSTALL THIS SYSTEM. IN ALL CASES, IT IS CRITICAL THAT THE INSTALLATION BE DONE IN ACCORDANCE WITH THESE INSTRUCTIONS AND ALL APPLICABLE PLUMBING AND ELECTRICAL CODES. BE SURE TO OBTAIN ALL REQUIRED PERMITS. IF THESE INSTRUCTIONS AND THE APPLICABLE CODES ARE IN CONFLICT, THE RELEVANT PLUMBING/ELECTRICAL CODE SHALL BE FOLLOWED. EQUIPMENT FAILURE, PERSONAL INJURY, OR PROPERTY DAMAGE CAN RESULT IF THIS EQUIPMENT IS NOT INSTALLED PROPERLY.**

## Step 1. – Pre-Installation Inspection

Inspect all of the components that you received with your unit. You should have received the following:

1. Fleck 5800 SXT Control Valve
2. Media Tank
3. Upper Screen
4. Bypass Assembly w/ 1" NPT Connector Yoke and Flow restrictor (attached)
5. Riser Tube and Lower Distributor
6. Bag or Box of Gravel
7. Bag(s) or Box(es) of MetSorb media
8. Funnel
9. Drain Line Flow Control - DLFC (attached to #1)
10. Arsenic Test Kit

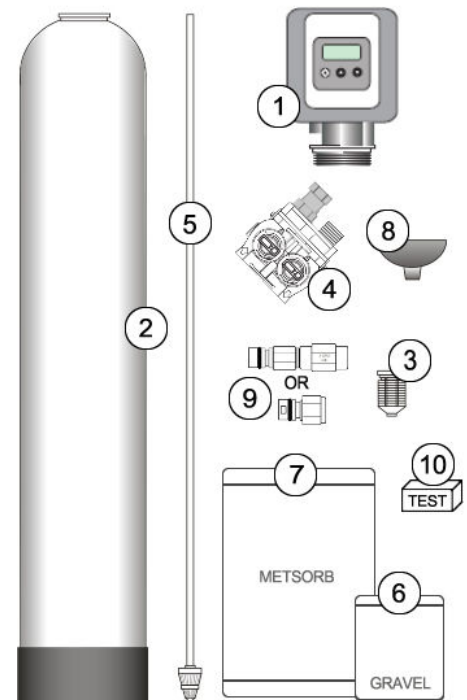

## Step 2. – Selecting an Installation Location

While exterior installation in warm climate areas is possible, we strongly recommend interior installation only. The system cannot be allowed to freeze or severe system damage could occur. The system should not be exposed to rain and it should not be installed in direct sunlight, as long-term exposure to UV light could damage components of the system. Furthermore, direct sunlight could raise the internal water temperature in the treatment tank and reduce backwash effectiveness.

In most cases, the system should be located AFTER your water pump and pressure tank(s) and BEFORE all other water treatment equipment and your hot water heater.



**IF YOU HAVE OTHER WATER TREATMENT EQUIPMENT, YOU SHOULD DISCUSS THE ORDER OF YOUR TREATMENT EQUIPMENT WITH YOUR DEALER PRIOR TO INSTALLATION.**

Select a location for installation of your water filter that is within close proximity to the main incoming water line of the home. The location should have a firm, level surface with enough space for the unit itself and sufficient space surrounding the unit to facilitate maintenance.



**WHILE WATER LEAKS ARE VERY RARE AND UNEXPECTED, YOUR WATER FILTER SYSTEM SHOULD BE LOCATED NEXT TO A FLOOR DRAIN OR PROTECTED BY A WATER LEAK DETECTION SYSTEM WITH AUTOMATIC SHUT-OFF VALVE TO PREVENT WATER DAMAGE TO YOUR PROPERTY IN THE UNLIKELY EVENT OF A WATER LEAK. RECOMMENDED WATER LEAK DETECTION SYSTEMS ARE AVAILABLE AT [WWW.A-LEAK-DETECTOR.COM](http://WWW.A-LEAK-DETECTOR.COM).**

You will also require a suitable drain to discharge waste water from the backwash cycle. A drain standpipe for a washing machine, floor drain, or sump pump are excellent drain options. We recommend that the drain line be connected to a minimum 1 1/2" drain standpipe or floor drain located ideally below the top of the head of your water filter. If possible, the drain should be no farther than 20 feet from the system.





**NOTE: NEVER CONNECT THE DRAIN LINE DIRECTLY INTO A DRAIN PIPE. ALLOW AN AIR GAP BETWEEN THE DRAIN TUBING AND WASTE LINE TO PREVENT THE POSSIBILITY OF BACK-SIPHONING. WE DO NOT RECOMMEND USE OF A CHECK VALVE AS IT MAY BECOME CLOGGED WITH CONTAMINANTS EJECTED FROM THE SYSTEM DURING BACKWASH.**

You will also need access to a standard, non-switched, grounded 120 volt (60 Hz) electrical outlet. An extension cord may be used to reach a suitable electrical outlet. If this option is used, ensure that the extension cord is UL/CSA certified and of an appropriate wire gauge for the application.

### **Step 3. – Prepare Treatment Tank**

Two types of media are supplied with your TITAN-Ox™ system: gravel which forms the base layer (underbedding) in your treatment tank, and a specialized water treatment media called MetSorb.

Place the tank in the location where it will sit when the installation is complete. Note that the black base of your tank is not permanently attached to the rest of the tank. If your tank appears to be crooked, the base has likely been knocked out of alignment during shipping. This can be corrected by picking the tank up and tapping it on a hard surface while holding it perpendicular to the floor. A few light taps will generally straighten it out.

Temporarily remove the distributor and riser tube assembly from the treatment tank. Hand tighten the Fleck 5800SXT control valve on the tank and mark where the front of the tank will be. Turn the tank so that the front of the tank is where you want it when it is full – once it is full of media and water, it becomes very heavy and difficult to move!

Remove the control valve and re-insert the distributor and riser tube assembly into the tank. The distributor, which looks like a cone-shaped plastic screen, is pre-connected to the end of the long plastic riser tube which extends from the bottom of the tank to the top of the tank where the control valve is attached. At the bottom of the tank, there is a recess in the center of the tank to accept the distributor to keep it properly aligned. The riser tube has been pre-cut to the correct height for you. When the distributor is correctly positioned, the top of the riser tube will be approximately 1/8 to 1/4 of an inch below the top of the tank. If the tube is

flush or protruding above the top of the tank, the distributor tube is not nested correctly in the recess at the bottom of the tank.

Add enough water to the tank to cover the lower distributor with a minimum of 6 inches of water. This will prevent damage to the lower distributor as gravel is loaded. Place the funnel into the tank so that the riser tube is in the middle. Place tape over the open end of the riser tube. This will prevent gravel or media from accidentally going down the tube during the following steps.

For the following steps, we recommend that you wear a dust mask. Take the bag/box of gravel and, using a small scoop, add the gravel to the tank through the funnel to completely cover the lower distributor. Use all of the gravel. Be sure to provide some downward pressure on the riser tube while adding the gravel to ensure that the distributor does not shift out of its recess or rise up. Ensure that you create an even layer of gravel across the bottom of the tank. A rigid piece of thin wall tubing (conduit, copper pipe, etc.), approximately 1" longer than the tank height works well as a leveling tool if you need it. Ensure that the riser tube remains centered in the opening at the top of the tank.

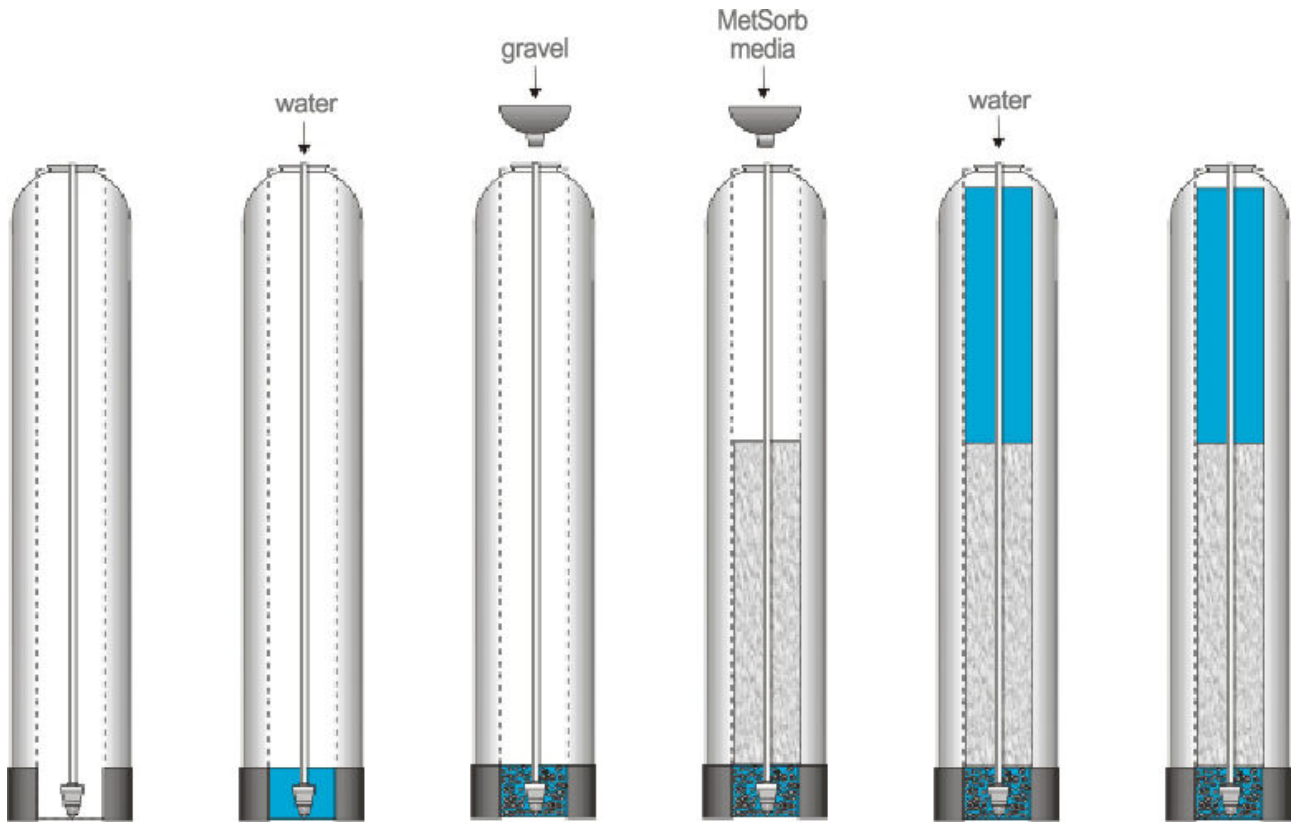

Once this is complete, add the MetSorb media in the same manner. Use all of the media provided. Depending on the capacity of the system, there will only be enough media to fill the tank to about 1/2 to 3/4 full. This is normal. The media tank should never be filled to the top of the tank as the remaining space, known as the “freeboard,” is necessary for the media to have room to expand during the backwash cycle.

Once you have finished adding the media to the tank, remove the tape from the distributor tube. Be careful not to pull upwards on the riser tube while doing this as it is important that the distributor remain in its recess at the bottom of the tank.

Fill the media tank with water up to within a couple of inches of the top of the tank. This will allow the media to pre-soak, thereby preventing media loss during the initial backwash.

## **WARNING**

**DO NOT INITIATE A REGENERATION OF THIS SYSTEM FOR A MINIMUM OF 2 HOURS AFTER ADDING THE WATER TO ALLOW ADEQUATE PRE-SOAKING. BACKWASHING BEFORE THE MEDIA IS SATURATED MAY CAUSE A LOSS OF MEDIA AND POTENTIAL DAMAGE TO THE CONTROL VALVE.**

Attach the upper screen to the underside of the control valve. Be sure to twist clockwise and lock it into place.

Apply a small amount of lubricant to the top inch of the outside of the riser tube and to the tank o-ring seal.

**Note: Only use food-grade silicone lubricant. A small bag of lubricant is provided in the small parts bag. Do NOT use petroleum jelly.**

The control valve can now be secured to the top of the tank. Before attaching the valve, check to make sure that there is no debris such as gravel or media in the tank threads. Screw the control valve onto the tank – make sure that the riser tube inserts into the center hole in the upper screen and the control valve as you screw down the valve. The control valve should be hand-tightened

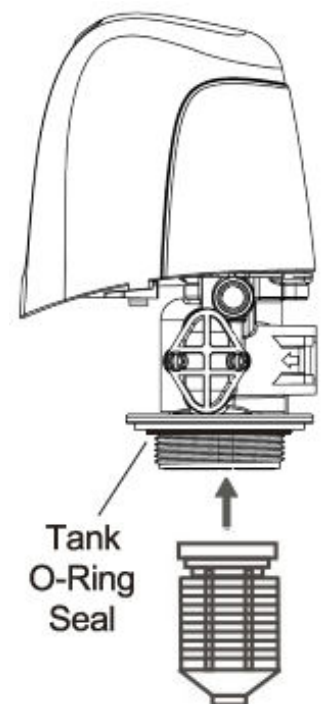

(clockwise). Do NOT use the control valve's timer assembly for leverage and do not use tools. A firm grasp with both hands at the base of the valve will work. Do NOT use pipe cement ("pipe dope") or Teflon® tape on the threads.

#### Step 4. – Turn off the Water & Electric Water Heaters



**FAILURE TO FOLLOW THIS PROCEDURE COULD RESULT IN SERIOUS, PERMANENT DAMAGE TO THE HEATING ELEMENTS IN YOUR WATER HEATER.**

If you have a conventional electric water heater or an on-demand (tankless) electric water heater, we highly recommend that you turn off the power to the heater while installing any water treatment equipment. Turn off power to your water heater now.

Turn off the household main water shutoff valve. Open several plumbing fixtures inside the home as well as the outside faucets to drain as much water out of the plumbing system as possible.

Following completion of the entire installation, restore the water flow by turning on the household main water valve and allow all air to be purged from the plumbing system before turning the power back on to your water heater.

#### Step 5. – Prepare and Install Inlet and Outlet Plumbing Connections



**TEFLON® TAPE IS THE ONLY SEALANT TO BE USED ON THE 1" NPT CONNECTOR YOKE AND DRAIN FITTINGS.**



**IF YOU WISH TO USE COPPER PIPING FOR YOUR INSTALLATION AND WILL BE SOLDERING THE JOINTS, DO NOT APPLY HEAT NEAR YOUR CONTROL VALVE, BYPASS ASSEMBLY, 1" NPT CONNECTOR YOKE, FLOW RESTRICTOR, OR THE DRAIN FITTINGS; OTHERWISE SERIOUS DAMAGE TO THESE PARTS COULD OCCUR. ALWAYS SOLDER JOINTS WITH THESE COMPONENTS DETACHED. IF YOU ARE USING COPPER**

**ADAPTERS TO CONNECT TO THE 1" NPT CONNECTOR YOKE, IT IS RECOMMENDED THAT YOU SOLDER A 6" PIECE OF COPPER PIPE INTO EACH OF THE CONNECTION ADAPTERS AWAY FROM THE VALVE, THEN LET THEM COOL OFF BEFORE THREADING THEM ONTO THE 1" NPT CONNECTOR YOKE.**

**Key Control Valve Components:**

1. Control Valve Body
2. Bypass Assembly
3. 1" NPT (Male) Connector Yoke
4. Stainless Steel Clip w/ Screw
5. Drain Line Flow Control (DLFC)
6. Valve Cover
7. DLFC Retention Clip
8. Flow Restrictor

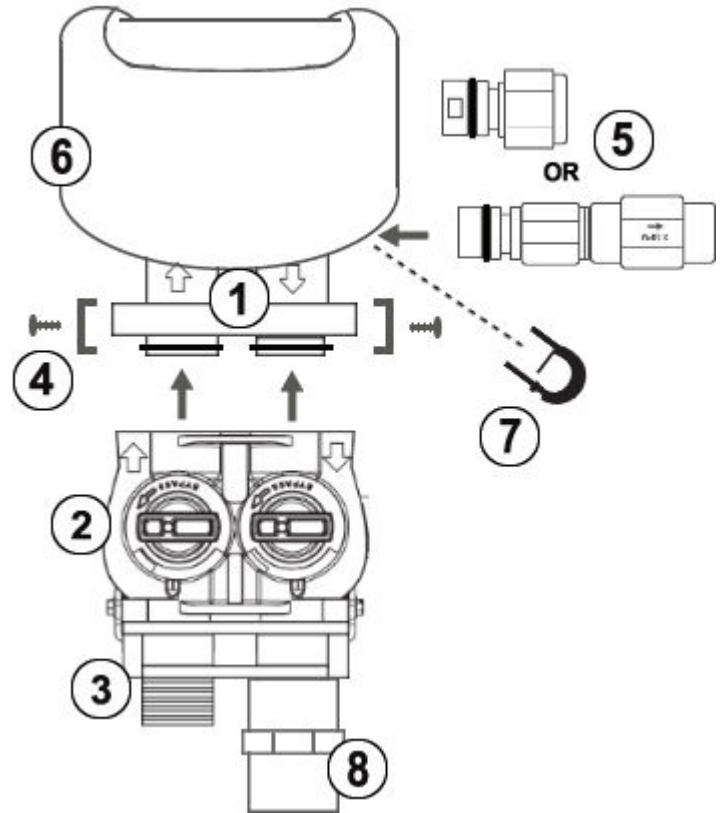

The system's control valve is connected to your incoming and outgoing water lines by way of a bypass assembly with 1"NPT threaded fittings. This assembly is composed of the bypass valve and the 1"NPT connector yoke. The 2 piece

bypass assembly is secured to the control valve using 2 stainless steel clips. Similarly, the 2 pieces of the bypass assembly, the bypass and the 1" NPT connector yoke, are connected to each other in the same manner (they are normally shipped to you pre-connected, but you can separate them to make plumbing easier if you want). A flow restrictor is installed on the outlet side of the connector yoke to ensure that your water flow rate does not exceed the maximum level recommended for your model. You will need to purchase the appropriate NPT threaded fittings to connect the bypass assembly to the material and size of your main inlet and outlet water lines.

Locate the inlet and outlet ports on the back of the control valve. Note that the inlet and outlet are marked with arrows indicating the correct direction of water flow. When you are looking at the back of the control valve, the inlet is on the left and the outlet is on the right. Check the corresponding markings on the bypass to ensure the correct direction of water flow and insert the bypass (do not secure the clips yet). The in and out arrows on the bypass

should be pointing the same direction as the in and out arrows on the outside of the control valve.

## CAUTION

**BE VERY CAREFUL TO MAKE SURE YOU PLUMB THE SYSTEM IN THE RIGHT DIRECTION.**

Plumb your main incoming and outgoing water lines using suitable pipe, fittings, elbows, etc. as necessary to create a tidy, secure installation up to the back of the bypass valve (including the correct connection adapters to mate with the threaded fittings on bypass assembly's connection yoke and flow restrictor. Be sure to follow all local plumbing codes.

## WARNING

**WE HIGHLY RECOMMEND THAT YOU REMOVE THE BYPASS ASSEMBLY FROM THE CONTROL VALVE BEFORE MAKING THESE FINAL CONNECTIONS AS YOU MAY INADVERTENTLY APPLY TOO MUCH PRESSURE ON THE VALVE WHILE SECURING THE ADAPTERS, CAUSING DAMAGE TO THE VALVE BODY.**

Once all plumbing to the bypass has been completed, you can connect the bypass assembly to the control valve. Push the bypass onto the back of the control valve and secure it using the two stainless steel clips with screws located on the back of the control valve. Do not overtighten - it is normal for some “play” to exist when the bypass assembly is properly seated. This allows for minor misalignment of the piping connections and relieves stress on the valve. **Place the bypass in the “bypass” position as pictured:**

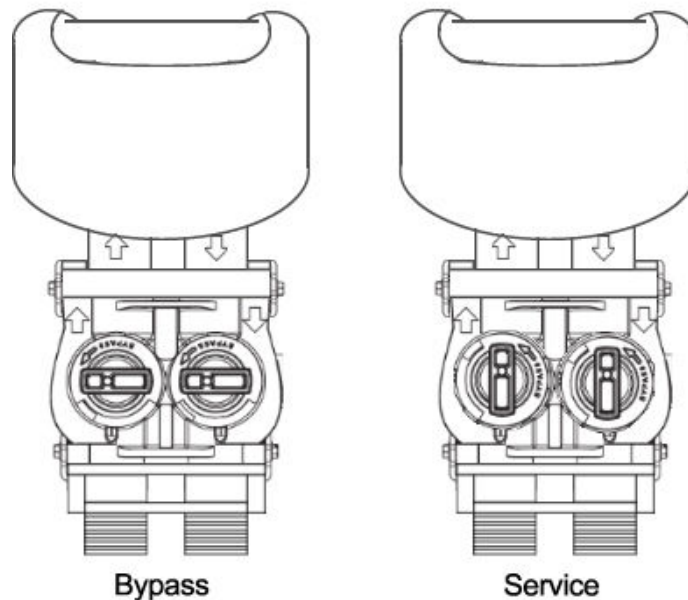

## Step 6. – Drain Line Installation



**NOTE: NEVER CONNECT THE DRAIN LINE DIRECTLY INTO A DRAIN. ALLOW AN AIR-GAP OF A MINIMUM OF 1 INCH (CHECK LOCAL CODES) BETWEEN THE DRAIN LINE AND WASTE LINE TO PREVENT THE POSSIBILITY OF BACK-SIPHONING. ALWAYS FOLLOW LOCAL CODES. THE DRAIN LINE SHOULD NOT BE EXPOSED TO FREEZING TEMPERATURES.**

During the backwash cycle, your TITAN-Ox™ will send captured contaminants out the drain port. This port needs to be connected to a suitable household drain, ideally within 20 feet of your media tank. A nearby floor drain, sump pump, or a standpipe for a washing machine is an excellent option. We recommend that the drain line be connected to a minimum 1 1/2 inch drain standpipe or floor drain located ideally below the top of the head of your water filter.

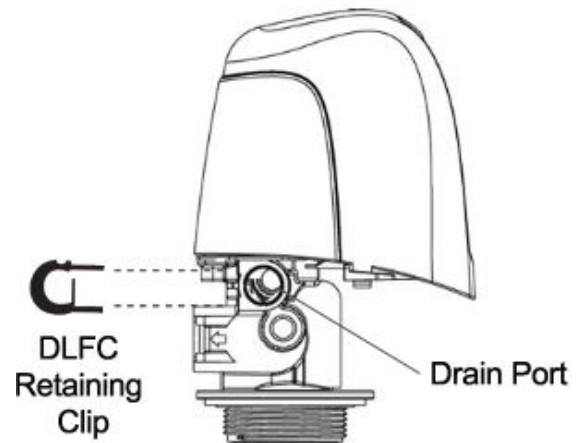

Locate the drain port on the back of your control valve. (DLFC) is pre-attached to the control valve. For backwash flow rates exceeding 7 GPM, the DLFC will be a brass adapter with a pre-attached external flow restrictor with 3/4 inch female NPT threads. For backwash flow rates below 7 GPM, the DLFC will be a black plastic housing with 1/2 inch female NPT threads. This housing contains a flow control washer that limits the backwash flow rate.

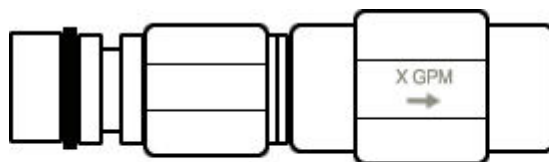

Drain Line Flow Restrictor  
For High-Flow Applications  
(Brass and/or Stainless Steel)

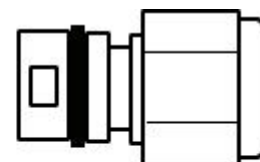

Drain Line Flow Restrictor  
For Lower-Flow Applications  
(Plastic)

You will need to purchase suitable pipe or tubing for the drain line, either 1/2 or 3/4 inch diameter, to match the connection points on the drain line flow control assembly (DLFC). To

determine your MINIMUM drain line diameter, look up your model and incoming water temperature using the chart below. **If in doubt, use a 3/4 inch drain line.**

**MINIMUM Drain Line Diameter:**

| Model             | 40F Water Temp | 70F Water Temp |
|-------------------|----------------|----------------|
| TOx-5800SXT-10-54 | 1/2"           | 1/2"           |
| TOx-5800SXT-12-52 | 1/2"           | 3/4"           |
| TOx-5800SXT-13-54 | 3/4"           | 3/4"           |
| TOx-5800SXT-14-65 | 3/4"           | 3/4"           |

Polyethylene tubing, PEX, PVC, CPVC, or copper pipe are all acceptable material choices for the drain line. If you are using flexible tubing, be sure that there are no “kinks” or “crimps” in the tubing after installation that may cause a flow restriction. If used, overhead drain lines are not to exceed a height of 5 feet above the control valve and should be not more than 50 feet in length. Should an overhead drain line be utilized, it is recommended that the drain line be increased in size (diameter), and that it not be fastened flush to the bottom of a floor joist to minimize noise transfer to the upstairs of the building during regeneration.

Using an appropriate fitting, connect the drain line flow control to your drain line tubing/pipe. The DLFC can be removed from the control valve to facilitate easier plumbing if desired. To remove the drain line flow control, pull on the retaining clip to remove it and then grasp the drain line flow control and pull outward. You may wish to dry-fit the fitting first to make sure you line up the drain line properly with the drain port on the control valve if you are using rigid pipe.

Re-insert the DLFC into the control valve and securely lock into place with the retaining clip when done.

Ensure that the drain line is thoroughly secured along its route to the drain. The drain line will be under pressure when the backwash cycle is working. If not adequately secured, the drain line could vibrate during backwash causing excessive noise. If this is experienced, use additional fixtures to better secure the drain line.

## **Step 7 – Control Valve Set-up**

During cold weather, the installer should warm the control valve to room temperature before operating. Note: All electrical connections must be done according to local codes.



Plug the control valve into a standard, grounded 120 volt (60 Hz) electrical outlet. Be certain that the outlet is uninterrupted and not controlled by a switch. An extension cord may be used to reach a suitable electrical outlet. Ensure that the extension cord is UL/CSA certified and of an appropriate wire gauge for the application. Plug the other end of the power cord into the electrical port on the control valve.

Note: The electrical port on the control valve is located on the right side of the valve (when you are facing the control panel), just behind the tab used to remove the valve cover. It is a bit tricky to find.

Once plugged in, the digital display on the control valve will illuminate. The control valve may need to reset to the home position when it is powered up. If it does, the motor will run for a few seconds.

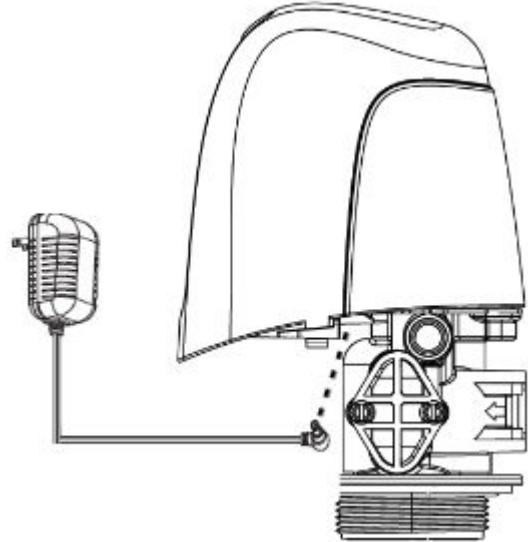

The digital display should be alternating between the current time setting (which is probably incorrect), and the number “10” which indicates the number of days remaining until the next backwash cycle. You will also see the “service” icon which appears as a small faucet in the bottom left corner of the display window.

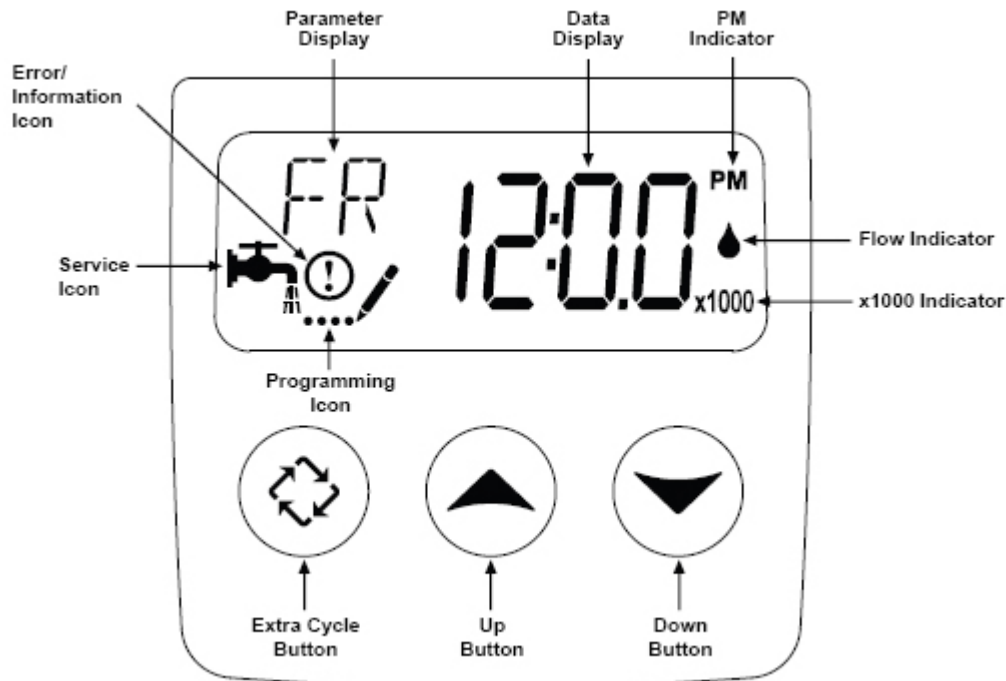

We will first set the time of day to the correct time. Press either the UP or DOWN button and hold for a few seconds. The parameter display will read “TD” (Time of Day) and the “programming” mode icon will appear (4 dots and a pencil). Use the UP and/or DOWN buttons to change the time displayed to the correct time of day. Once the display shows the correct time, press the EXTRA CYCLE button to save your changes.



Your TITAN-Ox™ has been pre-programmed to backwash every 10 days and to perform the backwash process at 12:30am in the morning when it is very unlikely that water will be required in the building. If water is required during the backwash process, untreated water will be permitted to flow to meet your service needs. You may edit the frequency and duration of the backwash based on your water conditions. You may also alter the time of day that the backwash process occurs if 12:30am is not ideal for you. If you have a water softener or other automatic backwashing water treatment systems, make sure that they are not set to backwash / regenerate at the same time. We recommend that they backwash/regenerate at least 2 hours apart. Follow the instructions under “User Programming Mode” to change the frequency or backwash time if desired. If you want to change the duration of the backwash or final rinse cycles, these settings must be edited in the “Master Programming Mode” – see below for details.

## Step 8 – Initial Start-up and Leak Testing

Ensure that the bypass is in the bypass position. Turn on the main water supply. Open a cold water tap nearby and let the water run for a few minutes or until the system is free of foreign material (usually solder) and air that may have resulted from the installation. Once the water is running clear and free of air, close the water tap.



**WARNING**  
**INSPECT YOUR PLUMBING CONNECTIONS AND CONTROL VALVE FOR LEAKS AND REPAIR ANY LEAKS FOUND BEFORE PROCEEDING.**



**DO NOT INITIATE A REGENERATION OF THIS SYSTEM FOR A MINIMUM OF 2 HOURS AFTER ADDING WATER TO THE MEDIA TANK TO ALLOW ADEQUATE PRE-SOAKING. BACKWASHING BEFORE THE MEDIA IS SATURATED COULD CAUSE A LOSS OF MEDIA AND POTENTIAL DAMAGE TO THE CONTROL VALVE.**

Once the media has been adequately pre-soaked for 2 hours:

WITH THE BYPASS STILL IN THE BYPASS POSITION, press the EXTRA CYCLE button and hold it down for about 5 seconds until you hear the valve change positions, the parameter display changes to read “BW” (Backwash), and the time starts counting down. Once the motor has stopped moving (no more noise), press the EXTRA CYCLE button again to advance to the next stage of the backwash cycle – “RR” (Rapid Rinse).

Without delay, immediately begin to slowly open the bypass to the service position, allowing water to flow into the system. Water and air will begin to flow to the drain line and will continue for 3 minutes. At the end of this time, the valve will re-position and the filter will return to normal service mode.



**INSPECT YOUR DRAIN LINE PLUMBING CONNECTIONS AND REPAIR ANY LEAKS IMMEDIATELY BEFORE PROCEEDING. IF THE PLUMBING PIPE RATTLED OR VIBRATED DURING THIS PROCESS CAUSING EXCESSIVE NOISE, USE ADDITIONAL FASTENERS TO BETTER SECURE THE DRAIN LINE.**

Press the EXTRA CYCLE button and hold it down for about 5 seconds to engage a full backwash and rinse cycle. Allow the backwash and rinse to run their full cycles.

When the system returns to service mode, slowly open a nearby cold water tap (after the TITAN-Ox™ system) and let the water run for 5 to 10 minutes until the system is purged of all air that may have resulted from the installation, and the water is running clear. Repeat for other faucets in the building starting at the highest elevation and working down to the lowest point until all air is purged. The initial flow of water may be slightly discolored. This is normal and will go away quickly.

It is now safe to turn the electricity back on to your water heater.

**Congratulations!**  
**Your system is now ready to provide treated water to your home!**

---

## PERFORMANCE MONITORING

The contaminants removed by this treatment system, including arsenic, uranium, lead and other heavy metals are harmful and can cause serious negative health effects. We strongly recommend a stringent ongoing water testing program to monitor the performance of your TITAN-Ox™ system. In the event that contaminant levels exceed U.S. EPA or Health Canada guidelines, your media may need to be replaced or backwash settings may need to be altered to improve contaminant reduction (to reduce channeling). Contact your dealer for advice and assistance.

We have included a basic arsenic monitoring testing kit (5 tests) with your system. This kit is ONLY for arsenic testing only. If you are monitoring other contaminants, you will need an alternate test kit or to use a certified water testing laboratory. Follow the test kit manufacturer's instructions very carefully to ensure accurate results. We recommend the following testing schedule following installation:

Test 1: within 24 hours of installation

Test 2: 25 days after installation

Test 3: 50 days after installation

Test at least every 2 to 3 months thereafter. Increase your testing frequency to monthly if contaminant levels begin to approach the maximum levels permitted by the U.S. EPA or Health Canada. **We strongly recommend that the first water test after installation, and at least one test annually thereafter, be performed by a certified water testing lab.**

The following are the maximum contaminant levels permissible in drinking water under U.S. EPA and Health Canada guidelines at the time of printing of this manual (subject to change):

| Contaminant | U.S. EPA Limit   | Health Canada Limit |
|-------------|------------------|---------------------|
| Arsenic:    | 0.010 mg/l (ppm) | 0.010 mg/l (ppm)    |
| Uranium:    | 0.03 mg/l (ppm)  | 0.02 mg/l (ppm)     |

|           |                  |                  |
|-----------|------------------|------------------|
| Lead:     | 0.015 mg/l (ppm) | 0.010 mg/l (ppm) |
| Selenium: | 0.05 mg/l (ppm)  | 0.01 mg/l (ppm)  |
| Antimony: | 0.006 mg/l (ppm) | 0.006 mg/l (ppm) |
| Mercury:  | 0.002 mg/l (ppm) | 0.001 mg/l (ppm) |
| Cadmium:  | 0.005 mg/l (ppm) | 0.005 mg/l (ppm) |
| Chromium: | 0.1 mg/l (ppm)   | 0.05 mg/l (ppm)  |

mg/l = milligrams per liter

ppm = parts per million

1 mg/l = 1 ppm

1,000 parts per billion = 1 part per million, so 0.010 ppm = 10 parts per billion (ppb)

## BACKWASH

The backwash process is automatically engaged and controlled by your Fleck 5800SXT valve. Your system was pre-programmed at the factory. In most cases, your system will be programmed to backwash every 10 days at 12:30am.

There are 2 steps to the backwash process:

Step 1: Backwash: factory pre-set for 10 minutes (parameter display code BW)

Step 2: Rapid Rinse: factory pre-set for 3 minutes (parameter display code RR)

Unless directed by a water treatment professional familiar with this system, we do not generally recommend that you alter the duration of any cycles, however, you can adjust the duration of both cycles based on your water conditions through the Master Programming Mode (see below). If you experience reduced service flow rate and pressure loss due to clogging, it is recommended that you increase the frequency and/or duration of your backwash. If on the mornings after a backwash your water is often discolored or has evidence of sediment, increase the duration of the rapid rinse cycle in 1 minute increments until the problem is resolved.

During each step of backwash, the digital display on the control valve will indicate the cycle currently underway and the amount of time remaining in that cycle.

There may be instances where more frequent backwash is required. For instance, if your water consumption increases considerably, or if your feed water conditions temporarily worsen, you may want to perform a manual backwash. You can choose to initiate a manual backwash immediately or the next time the backwash time of day is reached:

**To initiate a manual backwash the next time the backwash time of day is reached:**

Press the EXTRA CYCLE button once. The “service” icon will begin to flash indicating that a backwash is scheduled next time the backwash time of day is reached.

To cancel a queued backwash, press the EXTRA CYCLE button.

**To initiate an immediate manual backwash:**

Press the EXTRA CYCLE button and hold it down for 5 seconds until the backwash process begins.

**Skip through backwash steps:**

There may be times that it may be desirable to skip through backwash steps without allowing them to fully complete. This would be most typical during servicing. When a cycle engages, always wait until the motor has stopped before skipping to the next cycle. You can hear the valve motor while it is repositioning the valve at the beginning of each cycle. During the backwash process, you can advance to the next step by pressing the EXTRA CYCLE button.

The control valve will continue to keep time and the passage of days for a minimum of 48 hours in the event of power failure.

---

## **CHANGING TIME OF DAY**

During regular service mode, the digital display will alternate between the current time of day and the number of days until the next scheduled regeneration. For proper operation, it is important that the valve display the correct time of day. To change the time of day, press either the UP or DOWN button and hold for a few seconds. The “programming” icon will appear. Use the UP and/or DOWN buttons to change the time displayed to the correct time

of day. Once the display shows the correct time, press the EXTRA CYCLE button to save your changes.



---

## USER PROGRAMMING MODE

The User Programming Mode allows you to set the frequency of backwash and the time of day that backwash will take place.

To enter the User Programming Mode, press the UP and DOWN arrows at the same time and hold for 5 seconds until the “programming” mode icon appears. If the current time display is 12:01PM, you cannot enter the User Programming Mode – simply wait a minute before attempting.

The display will first show the **DAYS OVERRIDE** (parameter display code DO). This is the setting that determines the frequency of backwash (measured in days). It is generally recommend that the system backwash at least every 10 days. Failure to do so could result in loss of water pressure due to media clogging and channeling which can reduce system performance.

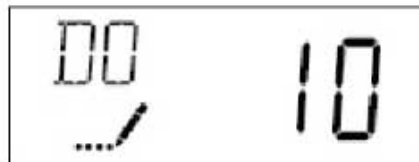

To change the setting, use the UP and DOWN buttons. Press the EXTRA CYCLE button when done. If you do not want to change the current setting, simply press the EXTRA CYCLE button to skip to the next step.

The display will now show the **REGENERATION (BACKWASH) TIME** (parameter display code RT). This is the setting that determines the time of day that the automatic backwash will start. It is strongly recommended that backwash be set to occur at night when water will not be in use. If you have other water treatment equipment that backwashes (such as a

water softener or iron filter), make sure that your TITAN-Ox™ is not set to backwash at the same time.

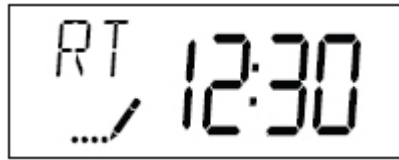

To change the setting, use the UP and DOWN buttons. Press the EXTRA CYCLE button when done. If you do not want to change the current setting, simply press the EXTRA CYCLE button to return to service mode.

The system should now return to normal service mode. The unit will also return to normal operation after 5 seconds if no buttons are pressed.

---

## MASTER PROGRAMMING MODE



**THE MASTER PROGRAMMING MODE IS DESIGNED FOR PROFESSIONAL USE ONLY. UNLESS DIRECTED BY A WATER TREATMENT PROFESSIONAL FAMILIAR WITH THE SYSTEM, IT IS STRONGLY RECOMMENDED THAT YOU DO NOT MODIFY ANY OF THE MASTER PROGRAMMING MODE SETTINGS**

To enter the Master Programming Mode, first set the time of day to 12:01PM. With the time display showing 12:01PM, enter the Master Programming Mode, by pressing the UP and DOWN arrows at the same time and holding for 5 seconds until the “programming” mode icon appears.

In this mode, you can adjust a parameter setting by using the UP and DOWN buttons. To save your changes and/or to skip to the next parameter, press the EXTRA CYCLE button. Press the EXTRA CYCLE button at the last parameter to save all settings and return to normal operation. The control will automatically disregard any programming changes and return to normal operation if it is left in Master Programming Mode for 5 minutes without any keypad input. The following settings are the factory default settings for all 5800SXT Series TITAN-Ox™ systems:



| Parameter         | Parameter Code | Option Code | Option Description |
|-------------------|----------------|-------------|--------------------|
| Display Format    | DF             | GAL         | Gallons            |
| Valve Type        | VT             | 5800        | Fleck 5800         |
| Regenerant Flow   | RF             | Fltr        | Filter             |
| Control Type      | CT             | tc          | Time Clock         |
| Day Override      | DO             | 10          | Every 10 days      |
| Regeneration Time | RT             | 12:30       | 12:30am            |
| Backwash          | BW             | 10          | 10 minutes         |
| Rapid Rinse       | RR             | 3           | 3 minutes          |

---

## RESETS



USE OF THE RESET FUNCTIONS IS NOT RECOMMENDED EXCEPT UNDER THE GUIDANCE OF A WATER TREATMENT PROFESSIONAL FAMILIAR WITH THIS EQUIPMENT.

**Soft Reset:** Press and hold the EXTRA CYCLE and DOWN buttons for 25 seconds while in normal Service mode. This resets all parameters to the system default values except days since backwash in the time clock system.

**Master Reset:** Hold the Extra Cycle button while powering up the unit. This resets all of the parameters in the unit. Check and verify the choices selected in Master Programming Mode.

---

## OPERATION DURING A POWER FAILURE

The 5800SXT valve/controller includes integral power backup. In the event of power failure, the control shifts into a power-saving mode. The display and motor shut down, but it continues to keep track of the time and day for a minimum of 48 hours.

The system configuration settings are stored in a non-volatile memory and are stored indefinitely with or without line power. The Time of Day flashes when there has been a power failure. Press any button to stop the Time of Day from flashing.

If power fails while the unit is in backwash, the control will save the current valve position before it shuts down. When power is restored, the control will resume the backwash cycle from the point where power failed. Note that if power fails during a backwash cycle, the valve will remain in its current position until power is restored.



**THE DRAIN LINE PLUMBING CONFIGURATION SHOULD INCLUDE ALL REQUIRED SAFETY COMPONENTS TO PREVENT OVERFLOWS RESULTING FROM A POWER FAILURE DURING BACKWASH.**

The control will not start a new backwash cycle without power. If the valve misses a scheduled backwash due to a power failure, it will queue a backwash. Once power is restored, the control will initiate a backwash cycle the next time that the Time of Day equals the programmed backwash time. Typically, this means that the valve will backwash one day after it was originally scheduled.

---

## MAINTENANCE & TROUBLESHOOTING



**THE CONTROLLER MUST BE DEPRESSURIZED BEFORE REMOVING ANY QUICK CONNECTION CLIPS OR THE VALVE ITSELF FOR SERVICING. THE CONNECTOR SHOULD BE PUSHED TOWARD THE CONTROL VALVE WHILE REMOVING CLIPS.**

### Service Recommendations

Your Fleck 5800 valve is built for long term operation with limited maintenance. The seals and spacers and piston assembly require periodic servicing or replacement, generally every 2 to 5 years. See Service Bulletin #5800-1 for instructions on this procedure.



**THE METSORB TITANIUM DIOXIDE MEDIA SHOULD BE REPLACED IF CONTAMINANT LEVELS FOUND DURING MONITORING TESTING EXCEED U.S. EPA OR HEALTH CANADA GUIDELINES.**

Inadequate backwash duration or flow rates could cause media clogging which could require the replacement of the media to restore flow and pressure performance.

### Troubleshooting

| PROBLEM  | CAUSE  | CORRECTION   |
|--|--|--|
| 1. Valve fails to backwash   | A. Electrical service to unit has been interrupted.<br>B. Timer is defective.  | A. Assure permanent electrical service (check fuse, plug, pull chain or switch).<br>B. Replace timer.  |
| 2. Loss of water pressure.   | A. Contaminant build-up in feed line.<br>B. Contaminant build-up in unit<br>C. Inlet of control plugged due to foreign material broken loose from pipe by recent work done on plumbing system. | A. Clean line to water filter.<br>B. Perform manual backwash. Increase frequency of regeneration and/or backwash time.<br>C. Remove pistons and clean control. |
| 3. Loss of media through drain line.                                   | A. Drain line flow control too large.  | A. Check to ensure drain line flow control is sized properly for your treatment tank.  |
| 4. Water running to drain during service mode.                         | A. Internal valve leak.<br>B. Jammed piston.   | A. Replace seals and spacers and/or piston.<br>B. Remove obstruction/debris and inspect seals and spacers and/or piston for damage.                            |
| 5. Cloudy water and/or poor water pressure after initial installation. | A. Additional backwash required.   | A. Perform 1 or more additional manual backwash cycles.  |

### ERROR CODES

| Code | Error           | Cause  | Reset & recovery  |
|------|-----------------|--|---|
| 0    | Cam Sense Error | The valve drive took longer than 6 minutes to advance to the next regeneration position. | Unplug the unit and examine the control valve. Verify that all cam switches are connected to the circuit board and functioning properly. Verify that the motor and drive train components are in good condition and |

|   |                  |   |   |
|---|------------------|---|---|
|   |                  |   | assembled properly. Check the valve and verify that the piston travels freely. Replace / reassemble the various components as necessary. Plug the unit back in and observe its behavior. The unit should cycle to the next valve position and stop. If the error re-occurs, unplug the unit and contact technical support.  |
| 1 | Cycle Step Error | The control experienced an unexpected cycle input.    | Unplug the unit and examine the control valve. Verify that all cam switches are connected to the circuit board and functioning properly. Enter Master Programming mode and verify that the valve type and system type are set correctly with regard to the unit itself. Step the unit through a manual regeneration and verify that it functions correctly. If the error re-occurs unplug the unit and contact technical support. |
| 2 | Regen Failure    | The system has not regenerated for more than 99 days. | Perform a Manual Regeneration to reset the error code. Enter Master Programming mode and verify that the unit is configured properly. As appropriate for the valve configuration, check that the correct system capacity has been selected, and that the day override is set properly. Correct the settings as necessary.   |
| 3 | Memory Error     | Control board memory failure.                         | Perform a Master Reset and reconfigure the system via Master Programming mode. After reconfiguring the system, set the valve through a manual regeneration. If the error re-occurs, unplug the unit and contact technical support.  |

---

## WARRANTY INFORMATION

TITAN-Ox™ systems are backed by a comprehensive warranty program.

The Fleck 5800SXT control valve and related bypass assembly and media tank are manufactured by Pentair LLC and are subject to Pentair LLC's Limited Warranty. See Pentair's Limited Warranty for details.

**Fleck 5800SXT control valve: 5 Years\***

**Media tanks up to 13" in Diameter: 10 Years**

## **Media tanks 14" and Greater in Diameter: 5 Years**

\*Note: Pistons and piston seals are considered wear and tear items and require regularly scheduled maintenance and replacement.

HomePlus Products Inc. will assist you in obtaining warranty coverage from Pentair LLC. To report a warranty problem with your system or request warranty assistance, please call HomePlus Products Inc. Toll free: 1-866-376-2690

**Subject to the limitations noted below, all other components of the TITAN-Ox™ system are warranted by HomePlus Products Inc. to be free of defects in material and workmanship for a period of 1 year except as noted\*\*.**

\*\*Note: Due to the wide variety of potential feed water conditions, there is no warranty on the MetSorb media or underbed gravel.

The term of these warranties begins on the date of delivery of the product to the customer and continues until the earlier of:

- the end of the warranty term noted above; or
- the date in which the product(s) is/are removed from the original location of installation; or
- the date in which the original purchaser sells or otherwise transfers ownership of the home in which the product(s) was/were originally installed.

Only products purchased from an Authorized Dealer or HomePlus Products Inc. directly are eligible for this warranty. The products must have been installed and operated in accordance with the instructions and operating conditions stated in the Owner's Manual.

Customer must register his or her warranty with HomePlus products Inc. within 90 days of original purchase for the warranty to remain valid.

This warranty applies only in Canada and the United States of America.

In the event that a part is deemed defective, the user must immediately inform HomePlus Products Inc. who will furnish a replacement part at no cost to the user. HomePlus' obligation to the customer shall be limited to the replacement of the defective part by prepaid standard freight to the original point of installation. Expedited shipping is available at the discretion and cost of the customer. When required, the return of defective parts to HomePlus is the responsibility of the customer.

This warranty does not cover any labour costs including labour costs related to troubleshooting, repair, installation, replacement, or maintenance.

This warranty does not apply to the following situations: misuse; normal wear and tear; neglect; unauthorized repair or damage caused through installation, adaptation, or modification; use in an improper manner or manner inconsistent with the manufacturer's installation, operating, and maintenance instructions; misapplication; wear or deterioration due to environmental conditions; damage occurring during transit; mishandling; improper storage; incorrect supply of water; tampering or alteration; fire, freezing; act of God; or any cause beyond the control of HomePlus Products Inc.

The original warranty period does not change in the event of part replacement by HomePlus Products Inc.

This warranty is issued exclusively to the original consumer purchaser of record so long as the product remains installed in the original location of installation, and is not transferable.

The provisions of the foregoing warranties are in lieu of any other warranty, whether expressed or implied, written or oral (including any warranty of merchantability or fitness for a particular purpose). HomePlus Product Inc.'s liability arising out of the manufacture, sale, or supplying of the products or their use or disposition, whether based upon warranty, contract, tort, or otherwise, shall not exceed the actual purchase price paid by the authorized dealer or consumer for the product. In no event shall HomePlus Products Inc. be liable to the distributor or any other person or entity for special, incidental, consequential or punitive damages (including, but not limited to, property damage or loss, loss of incomes, or loss of use damages) arising out of the manufacture, sale, or supplying of the products, even if HomePlus Products Inc. has been advised of the possibility of such damages or losses. These warranties are governed by the laws of the Province of British Columbia, Canada, and may change without notice.

To report a warranty problem with your system or request warranty assistance, please call HomePlus Products Inc. Toll free: 1-866-376-2690.

MANUFACTURED BY:



**HomePlus Products Inc.**

5-1490 Pearson Place  
Kamloops, BC V1S 1J9  
Canada

Phone: 250-374-2690

Fax: 250-374-2692

[www.homeplusproducts.com](http://www.homeplusproducts.com)